

Dialogic® DM3 Media Boards

Quick Install Card for PCI

DM/V480-4T1-PCI
DM/V600-4E1-PCI

DM/V960-4T1-PCI
DM/V1200-4E1-PCI

Dialogic®

Part Number 64-0041-02
Copyright © 2002-2007
Dialogic Corporation.
All Rights Reserved.

Before You Begin

Protecting the Board from Damage

CAUTION

All computer boards are sensitive to electrostatic discharge (“ESD”). Handle all static-sensitive boards and components at a static-safe work area, and observe anti-static precautions at all times.

If you are not familiar with ESD safety precautions, visit <http://www.dialogic.com/support/hwinstall> to learn more.

Unpacking the Board

Unpack the Dialogic® DM3 Media Board (“board”) according to the following steps:

1. Prepare a static-safeguarded work area.
2. Carefully remove the board from the shipping carton and anti-static packaging. Handle the board by the edges and avoid touching the board’s components.
3. Lay the board on the static-dissipative work surface.

Note: Place boards in static-shielding bags when carrying boards from station to station.

CAUTION: Do not remove the board from the anti-static packaging until you are ready to install it. Observe proper anti-static precautions at all times.

Configuring the Hardware

Board Identification

The device driver, part of the system software, assigns board instance numbers in ascending order (beginning with 0) as it detects each board in your system. A board instance number

Physical Description

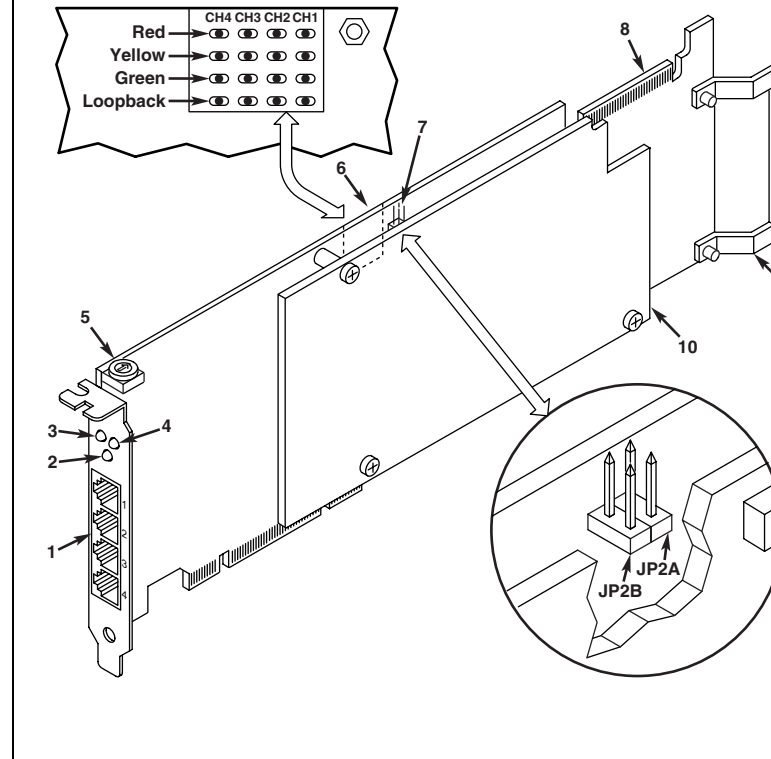

1. **J1–J4:** RJ-48C jacks to connect to external digital telephone network interface.
 2. **General Network Interface Alarm LED (yellow):** Indicates an alarm condition.
 3. **Power LED (green):** Indicates board is powered up.
 4. **Reset LED (red):** Indicates reset is activated.
 5. **SW1:** Rotary switch to set board identification (LINUX systems only).
 6. **Alarm LEDs:** Indicate network alarms for trunks (CH1–CH4).
Red—Indicates loss of signal.
Yellow—Indicates loss of frame synchronization at far end of external network.
Green—Indicates signal present; powered up and receiving signal from external sources.
Loopback—Indicates that loopback mode is activated.
 7. **CT/MVIP Bus Termination Jumpers*:** Bus signal is terminated when the corresponding jumper clip is installed.
JP2A—CT Bus termination jumper.
JP2B—MVIP Bus termination jumper.
 8. **P3:** CT Bus connector.
 9. **ISA Edge Retainer**
 10. **Signal Processing (SP) Daughterboard**
- *Note: Signal must be terminated only on boards at each end of the CT Bus cable.

is the identification (ID) number used by the system software to recognize the board.

NOTE: If you add or remove a board, the system may change the existing board instance (ID) numbers.

Windows System

Leave SW1 set to the factory default of Board ID 0 to let the system automatically assign board instance numbers by PCI bus slot number.

After the hardware and the system software are installed, refer to the Dialogic® Configuration Manager (DCM) utility to retrieve the assigned board instance (ID) number(s). For more information about board identification, see the DCM online help.

Linux System

In a Linux system, you **must** set SW1 to a unique number for each installed board. Use a non-magnetic screwdriver to turn SW1 to 1 of 16 board settings, 0–9 or A–F.

After the hardware and the system software are installed, refer to the proper configuration files to retrieve the assigned board instance (ID) number(s). For more information about Linux configuration files, see the *Software Installation Reference*.

Installing the Hardware

NOTE: If you are adding hardware to an existing system, you do not need to uninstall existing Dialogic® System Software.

1. Working with your computer at a static-safe work area, switch off the power and disconnect all power cords from the electrical outlets.
2. Remove the computer cover.
3. Select an empty PCI expansion bus slot and remove the slot’s retaining screw and access cover plate.
4. If you are not installing your board in an ISA form factor PCI slot, remove the ISA edge retainer bracket from the board.
5. Using the slot’s board guides, insert the edge connector of the board into the bus slot. Press firmly until the board is securely seated in the slot.

Installing a PCI Board

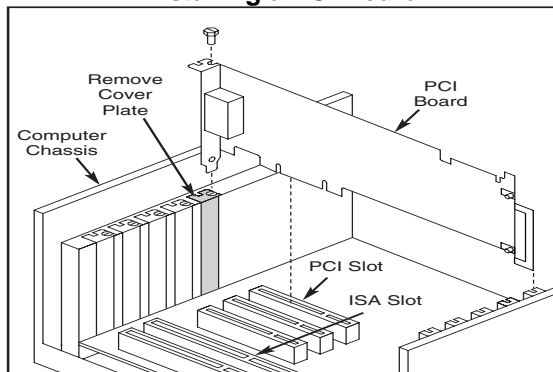

6. Replace and tighten the retaining screw to secure the board firmly in the chassis slot.
7. Connect the external digital telephone cables to the RJ-48C jacks (J1–J4) on the board bracket. See *Connecting to the RJ-48C Jacks* section.
8. Select a new PCI slot and repeat steps 3–7 for each board you are installing.
9. Use the CT Bus cable to connect the board(s) you are installing to other boards in the system.

Installing the CT Bus Cable

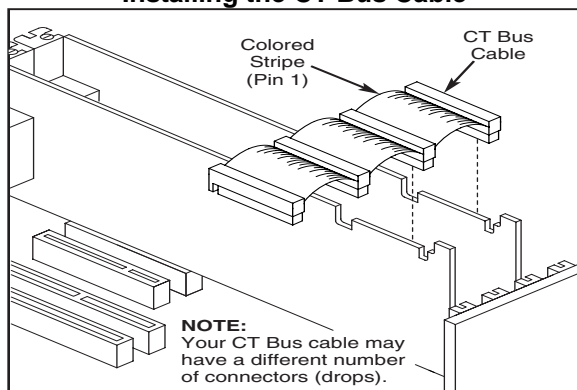

NOTE: Your system may include both CT Bus and SCbus boards. To connect both board types, you must install a CT Bus/SCbus Adapter on one of the CT Bus boards in the system. See the *CT Bus/SCbus Adapter Quick Install Card* for installation details about the Adapter and the bus cables. Contact your Sales Representative to order an Adapter.

10. Install CT Bus Termination Jumpers only on boards located at each end of the CT Bus cable. See *Physical Description* section.
11. Replace the computer cover when finished and reconnect the power cords.
12. Turn the power to the chassis **ON**.

CAUTION: If your BIOS is set to use Plug and Play technology and there are ISA boards in your system, an IRQ conflict can be created if a PCI board is assigned the same IRQ as an ISA board. This could cause the machine to stop responding. You can prevent this by entering the BIOS and reserving the appropriate IRQs (those used by your ISA boards) for ISA use only.

Connecting to the RJ-48C Jacks

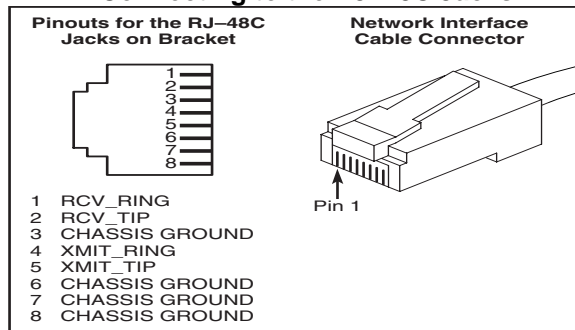

After Installing Hardware

After installing the hardware, run the Dialogic® Configuration Manager (DCM) as described in the installation instructions included with the Dialogic® System Software to configure your system.

For technical specifications and product information go to: <http://www.dialogic.com/products.htm>.

Warranty and Return Information

Warranty Period

For specific warranty information for this board, refer to the Warranty section of the Products page, located at this URL: <http://www.dialogic.com/warranties/>.

Contacting Technical Support

Dialogic provides technical support for its products through a network of value added distributors who are trained to answer technical questions on installing and configuring Dialogic® products. If you are unsure how to contact your support channel, please call Dialogic in the United States at 973-967-6600 (9am-5pm EST) and we will assist in obtaining the appropriate support channel. Outside the United States please refer to <http://www.dialogic.com/support/contact> to obtain local contact information. Dialogic also provides direct support via Dialogic® Pro™ Services agreements. For more details of direct support from Dialogic please refer to: <http://www.dialogic.com/support/DialogicPro>.

Returning a Product

To return for warranty repair or any other returns, please refer to the following: <http://www.dialogic.com/support/hwfaults>.

Sales Assistance

If you have a sales question, please contact your local Sales Representative or the Regional Sales Office for your area. Address, telephone and fax numbers, are available at the Dialogic website located at:

<http://www.dialogic.com/contact.htm>

To purchase Dialogic® products, please refer to the following website to locate the appropriate supplier:

<http://www.dialogic.com/purchase.htm>

All contents of this document are furnished for informational use only and are subject to change without notice and do not represent a commitment on the part of Dialogic Corporation or its subsidiaries ("Dialogic"). Reasonable effort is made to ensure the accuracy of the information contained in the document. However, Dialogic does not warrant the accuracy of this information and cannot accept responsibility for errors, inaccuracies or omissions that may be contained in this document.

INFORMATION IN THIS DOCUMENT IS PROVIDED IN CONNECTION WITH DIALOGIC® PRODUCTS. NO LICENSE, EXPRESS OR IMPLIED, BY ESTOPPEL OR OTHERWISE, TO ANY INTELLECTUAL PROPERTY RIGHTS IS GRANTED BY THIS DOCUMENT. EXCEPT AS PROVIDED IN A SIGNED AGREEMENT BETWEEN YOU AND DIALOGIC, DIALOGIC ASSUMES NO LIABILITY WHATSOEVER, AND DIALOGIC DISCLAIMS ANY EXPRESS OR IMPLIED WARRANTY, RELATING TO SALE AND/OR USE OF DIALOGIC PRODUCTS INCLUDING LIABILITY OR WARRANTIES RELATING TO FITNESS FOR A PARTICULAR PURPOSE, MERCHANTABILITY, OR INFRINGEMENT OF ANY INTELLECTUAL PROPERTY RIGHT OF A THIRD PARTY.

Dialogic products are not intended for use in medical, life saving, life sustaining, critical control or safety systems, or in nuclear facility applications.

It is possible that the use or implementation of any one of the concepts, applications, or ideas described in this document, in marketing collateral produced by or on web pages maintained by Dialogic may infringe one or more patents or other intellectual property rights owned by third parties. Dialogic does not provide any intellectual property licenses with the sale of Dialogic products other than a license to use such product in accordance with intellectual property owned or validly licensed by Dialogic and no such licenses are provided except pursuant to a signed agreement with Dialogic. More detailed information about such intellectual property is available from Dialogic's legal department at 9800 Cavendish Blvd., 5th Floor, Montreal, Quebec, Canada H4M 2V9. **Dialogic encourages all users of its products to procure all necessary intellectual property licenses required to implement any concepts or applications and does not condone or encourage any intellectual property infringement and disclaims any responsibility related thereto. These intellectual property licenses may differ from country to country and it is the responsibility of those who develop the concepts or applications to be aware of and comply with different national license requirements.**

Dialogic, Diva, Eicon, Eicon Networks, Eiconcard and SIPcontrol, among others, are either registered trademarks or trademarks of Dialogic. Dialogic's trademarks may be used publicly only with permission from Dialogic. Such permission may only be granted by Dialogic's legal department at 9800 Cavendish Blvd., 5th Floor, Montreal, Quebec, Canada H4M 2V9. Any authorized use of Dialogic's trademarks will be subject to full respect of the trademark guidelines published by Dialogic from time to time and any use of Dialogic's trademarks requires proper acknowledgement. The names of actual companies and products mentioned herein are the trademarks of their respective owners.