



# **Dialogic<sup>®</sup> IMG 1010/1004** **Integrated Media Gateways**

**SD CARD**  
**Release 10.3.x / 10.5.x**

# Copyright and Legal Notice

Copyright © 2005-2008 Dialogic Corporation. All Rights Reserved. You may not reproduce this document in whole or in part without permission in writing from Dialogic Corporation at the address provided below.

All contents of this document are furnished for informational use only and are subject to change without notice and do not represent a commitment on the part of Dialogic Corporation or its subsidiaries ("Dialogic"). Reasonable effort is made to ensure the accuracy of the information contained in the document. However, Dialogic does not warrant the accuracy of this information and cannot accept responsibility for errors, inaccuracies or omissions that may be contained in this document.

INFORMATION IN THIS DOCUMENT IS PROVIDED IN CONNECTION WITH DIALOGIC® PRODUCTS. NO LICENSE, EXPRESS OR IMPLIED, BY ESTOPPEL OR OTHERWISE, TO ANY INTELLECTUAL PROPERTY RIGHTS IS GRANTED BY THIS DOCUMENT. EXCEPT AS PROVIDED IN A SIGNED AGREEMENT BETWEEN YOU AND DIALOGIC, DIALOGIC ASSUMES NO LIABILITY WHATSOEVER, AND DIALOGIC DISCLAIMS ANY EXPRESS OR IMPLIED WARRANTY, RELATING TO SALE AND/OR USE OF DIALOGIC PRODUCTS INCLUDING LIABILITY OR WARRANTIES RELATING TO FITNESS FOR A PARTICULAR PURPOSE, MERCHANTABILITY, OR INFRINGEMENT OF ANY INTELLECTUAL PROPERTY RIGHT OF A THIRD PARTY.

Dialogic products are not intended for use in medical, life saving, life sustaining, critical control or safety systems, or in nuclear facility applications.

Due to differing national regulations and approval requirements, certain Dialogic products may be suitable for use only in specific countries, and thus may not function properly in other countries. You are responsible for ensuring that your use of such products occurs only in the countries where such use is suitable. For information on specific products, contact Dialogic Corporation at the address indicated below or on the web at <http://www.dialogic.com/>.

It is possible that the use or implementation of any one of the concepts, applications, or ideas described in this document, in marketing collateral produced by or on web pages maintained by Dialogic may infringe one or more patents or other intellectual property rights owned by third parties. Dialogic does not provide any intellectual property licenses with the sale of Dialogic products other than a license to use such product in accordance with intellectual property owned or validly licensed by Dialogic and no such licenses are provided except pursuant to a signed agreement with Dialogic. More detailed information about such intellectual property is available from Dialogic's legal department at 9800 Cavendish Blvd., 5th Floor, Montreal, Quebec, Canada H4M 2V9.

**Dialogic encourages all users of its products to procure all necessary intellectual property licenses required to implement any concepts or applications and does not condone or encourage any intellectual property infringement and disclaims any responsibility related thereto. These intellectual property licenses may differ from country to country and it is the responsibility of those who develop the concepts or applications to be aware of and comply with different national license requirements.**

Any use case(s) shown and/or described herein represent one or more examples of the various ways, scenarios or environments in which Dialogic® products can be used. Such use case(s) are non-limiting and do not represent recommendations of Dialogic as to whether or how to use Dialogic products.

Dialogic, Dialogic Pro, Brooktrout, Cantata, SnowShore, Eicon, Eicon Networks, Eiconcard, Diva, SIPcontrol, Diva ISDN, TruFax, Realblobs, Realcomm 100, NetAccess, Instant ISDN, TRXStream, Exnet, Exnet Connect, EXS, ExchangePlus VSE, Switchkit, N20, Powering The Service-Ready Network, Vantage, Making Innovation Thrive, Connecting People to Information, Connecting to Growth and Shiva, among others as well as related logos, are either registered trademarks or trademarks of Dialogic. Dialogic's trademarks may be used publicly only with permission from Dialogic. Such permission may only be granted by Dialogic's legal department at 9800 Cavendish Blvd., 5th Floor, Montreal, Quebec, Canada H4M 2V9. Any authorized use of Dialogic's trademarks will be subject to full respect of the trademark guidelines published by Dialogic from time to time and any use of Dialogic's trademarks requires proper acknowledgement.

Windows is a registered trademark of Microsoft Corporation in the United States and/or other countries. Other names of actual companies and products mentioned herein are the trademarks of their respective owners.

This document discusses one or more open source products, systems and/or releases. Dialogic is not responsible for your decision to use open source in connection with Dialogic products (including without limitation those referred to herein), nor is Dialogic responsible for any present or future effects such usage might have, including without limitation effects on your products, your business, or your intellectual property rights.

# Hardware Limited Warranty

**Warranty for Hardware Products:** Dialogic Corporation or its subsidiary that originally sold the hardware product ("Dialogic") warrants to the original purchaser of this hardware product, that at the time of delivery the hardware product supplied hereunder will be free from defects in material and workmanship. This warranty is for the standard period set out on Dialogic's website at <http://www.dialogic.com/warranties> and is subject to all of the terms and limitations set out on the Dialogic website at <http://www.dialogic.com/warranties>.

**Additional Exclusions:** Dialogic will have no obligation to make repairs or replacements necessitated by your fault or negligence, improper or unauthorized use of the product, repairs or modifications made without Dialogic's prior written approval or by causes beyond the control of Dialogic, including, but not limited to, power or air conditioning failure, acts of God, improper interface with other units, or malfunction of any equipment or software used with the Dialogic product(s). If Dialogic is requested and agrees to make repairs or replacements necessitated by any such causes, you will pay for such service or replacement at Dialogic's then prevailing rates.

**No Other Warranties:** DIALOGIC DISCLAIMS AND YOU WAIVE ALL OTHER WARRANTIES, EITHER EXPRESS OR IMPLIED, INCLUDING BUT NOT LIMITED TO IMPLIED WARRANTIES OF MERCHANTABILITY, NON-INFRINGEMENT AND FITNESS FOR A PARTICULAR PURPOSE AND ANY WARRANTY AGAINST LATENT DEFECTS, WITH RESPECT TO ANY DIALOGIC PRODUCT.

**No Liability for Damages:** IN NO EVENT SHALL DIALOGIC OR ITS SUPPLIERS BE LIABLE FOR ANY DAMAGES WHATSOEVER (INCLUDING, WITHOUT LIMITATION, DAMAGES FOR LOSS OF PROFITS, INTERRUPTION OF ACTIVITIES, LOSS OF INFORMATION OR OTHER PECUNIARY LOSS AND DIRECT OR INDIRECT, CONSEQUENTIAL, INCIDENTAL, ECONOMIC OR PUNITIVE DAMAGES) ARISING OUT OF THE USE OF OR INABILITY TO USE ANY DIALOGIC PRODUCT.

**Limitation of Liability:** DIALOGIC'S MAXIMUM CUMULATIVE LIABILITY SHALL BE LIMITED TO THE AMOUNTS ACTUALLY PAID BY YOU TO DIALOGIC FOR THE SPECIFIC PRODUCT BEING THE OBJECT OF THE CLAIM. YOU RELEASE DIALOGIC FROM ALL AMOUNTS IN EXCESS OF THE LIMITATION. YOU ACKNOWLEDGE THAT THIS CONDITION IS ESSENTIAL AND THAT DIALOGIC WOULD NOT SUPPLY TO YOU IF IT WERE NOT INCLUDED.

## IMPORTANT NOTE:

Please be aware that the following terminology and abbreviations are used throughout this document. Please also be sure to consult the legal notice for other important details.

When used herein, the term "IMG 1010" refers to the "Dialogic<sup>®</sup> IMG 1010 Integrated Media Gateway" product.

When used herein, the term "IMG 1004" refers to the "Dialogic<sup>®</sup> IMG 1004 Integrated Media Gateway" product.

When used herein, the general term "IMG" refers collectively or alternatively to the Dialogic<sup>®</sup> IMG 1010 and the Dialogic<sup>®</sup> IMG 1004 Integrated Media Gateway products

When used herein, the term "GCEMS" refers to the "Dialogic<sup>®</sup> Gate Control Element Management System"

## Technical Support

Technical Support Number: 781-433-9600

Technical Support Fax: 781-449-9520

<http://www.dialogic.com/>

# Table Of Contents

IMG 1010 - SD Card .....	1
Downloading System Software Using Boot File on an SD Card - IMG 1010 .....	1
Downloading IMG System Software From an SD Card - IMG 1010 .....	4
Distributing System Software Using an SD Card - IMG 1010 .....	7
Default bootup.cfg Configuration File - IMG 1010 .....	8
SD Card Remote Provisioning - IMG 1010 .....	9
IMG 1004 - SD Card .....	13
Downloading System Software Using Boot File on an SD Card - IMG 1004 .....	13
Downloading System Software From an SD Card - IMG 1004 .....	16
Distributing System Software Using an SD Card - IMG 1004 .....	19
Default bootup.cfg Configuration File - IMG 1004 .....	20
SD Card Remote Provisioning - IMG 1004 .....	21

## IMG 1010 - SD Card

### Downloading System Software Using Boot File on SD Card - IMG 1010:

**Topic Location:** IMG 1010-Installation and Setup Guide > IMG 1010-SD Card

A BootP server is used to configure the following:

- IMG CTRL IP address
- subnet mask
- gateway address
- FTP server address
- FTP file name of the IMG 1010 system software

If a BootP server is not available but a remote FTP Server is available, the SD card can be used to configure the boot parameters so the IMG 1010 can retrieve the system software from the remote FTP Server. See Diagram Below.

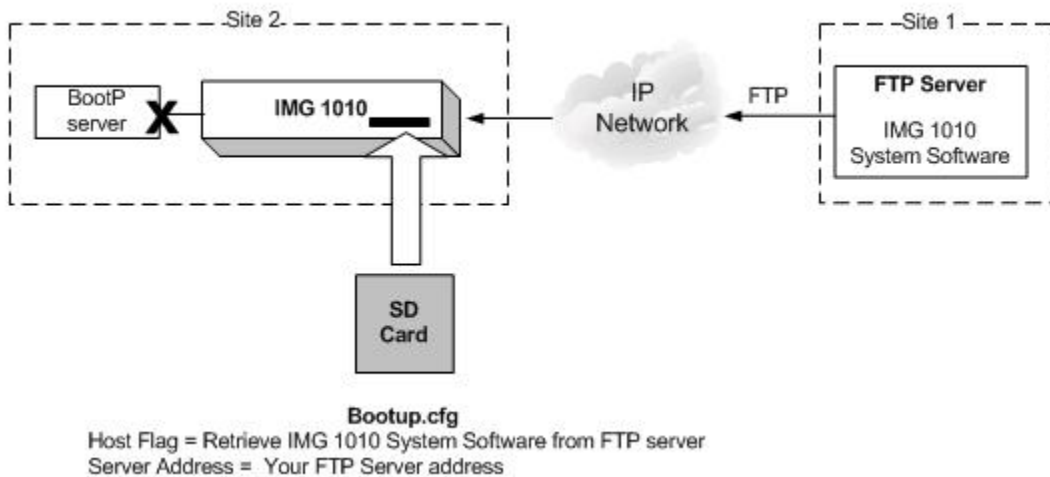

**STEPS:**

1. Insert the SD Card into an SD Writer connected to a PC.
2. On the SD Card is a file named bootup.cfg. Open this file.
3. Below is what the SD Card bootup.cfg information should look like.

```
#####  
#####  
# INSTRUCTIONS  
# 1. Edit values as required, as described below.  
# Change IP Address, Subnet Mask, and Gateway IP Address to the actual #values for the  
# IMG.  
# If you change the version of IMG System Software on the FTP Server #or the SD card,  
# make sure you change the System Software Filename #value.  
# Make sure Host Flag is set appropriately for your configuration and #Boot method  
#  
# Calculate boot flag by adding values based on desired system attributes  
# For a T1 system: add 0  
# For an E1 system: add 2  
#  
# To boot from a FTP Server: add 0  
# To boot from a SD Card: add 32  
#  
# For LBR codecs (512 ch/mod): add 0  
# For LBR + ILBC codecs (336 ch/mod): add 16  
# For LBR + ILBC + Wireless codecs (336 ch/mod): add 24  
#  
# An example host flag for a T1 system booting from the SD card with LBR + iLBC codecs  
# would = 48 (0+32+16)  
# Change Server Address to the actual address of the FTP server.  
# The Server Name is not used at this time.  
# 2. After editing this file: save file, remove SD card, insert SD card #in the IMG, power-up  
# the IMG.  
#-----  
# IMG bootup configuration file  
# IP Address  
yiaddr=192.168.3.103  
# Subnet Mask  
subnet mask=255.255.255.0  
# Gateway Address  
giaddr=192.168.3.10  
# System Software Filename  
file=/excelsw/ftpBuilds  
# Host Flag  
host flag=0  
# Server Address for File transfer and SNTP operation.  
siaddr=192.168.1.100  
# Server Name (Optional, not currently used)  
sname=factorydefault  
#####  
#####
```

4. Any line beginning with the # symbol is a comment and is not processed by the IMG 1010. Below is the information the user will edit for use in their network
  - **yiaddr** --> IP Address of the IMG 1010 being loaded
  - **subnetmask** --> Subnet mask of the IMG 1010 being loaded
  - **giaddr** --> IP Address of the Gateway connected to the IMG 1010
  - **file** --> If using the SD card to supply boot information but loading software from the FTP Server the System Software Filename on the bootup.cfg file should be given a path to the IMG 1010 System Software file located on the ftp server. The default path is /excelsw/ftpBuilds or ftpBuilds/ as the IMG 1010 logs into the FTP server using the excelsw account.
  - **Host flag** --> The Host Flag informs the IMG 1010 of configuration details such as T1 or E1, Boot from SD card or Boot from FTP Server, and other configuration details. See Setting Host Flags.
  - **siaddr** --> IP Address of FTP server which provides the IMG 1010 System Software and NTP Server information
  - **sname** --> Optional (not currently used). Do not edit this.

5. Change the Host Flag to "Retrieve IMG Build from SD Card".

Host Flag Values

32 = Boot from SD Card, T1 system

34 = Boot from SD Card, E1 system

**Example:** The following is a T1 system booting from SD Card. Refer to the file Setting Host Flags to follow the example

Boot From SD card = 32

T1 system = add +00

Host Flag Value = 32

The Host Flag for a T1 system booting from SD Card = 32

6. Edit the bootup.cfg file to reflect the new Host Flag value
7. Edit the System Software Filename in the bootup.cfg file to reflect the new software file being loaded. (Ex: file=/excelsw/ftpBuilds)
8. Edit the rest of the bootup.cfg file to reflect your network values.
9. Save the bootup.cfg file.
10. Remove the SD card from the SD Writer.
11. Insert the SD card into the SD slot on the Front Panel of the IMG.
12. Power-up the IMG 1010. The fans will run at full speed while diagnostics are running and software is being loaded
13. The LCD screen will show the following:

While software is loading to the IMG 1010 the LCD screen will display the following

**MAC: 00:20:1C:04:03:11 ID:0101**  
**SDC Loading**

After the software has loaded to the IMG 1010 the LCD screen will display the following

**MAC: 00:20:1C:04:03:11 ID:0101**  
**Load OK/Jumping to Load**

After software is done loading, the LCD screen will display the node info and the fans will slow to normal operation

**Node Name: IMG1010**  
**Node ID: 255**

14. The loading of software and configuring of network information is now complete. The IMG 1010 is now ready to be configured.

## Downloading IMG System Software from SD Card - IMG 1010:

**Topic Location:** IMG 1010-Installation and Setup Guide > IMG 1010-SD Card

### Overview of SD Card

If the IMG 1010 does not have access to an FTP server, then the IMG 1010 System Software and IP information can be loaded through the use of an SD Card. The SD Card is a small memory card like the memory cards used in digital cameras and other devices. The IMG 1010 has an SD card slot positioned on the right hand side of the front panel just below the USB port. The SD card holds the `bootup.cfg` file and the IMG 1010 System Software file. The procedure below will explain how to load the IMG 1010 System Software and IP addresses using just the SD Card.

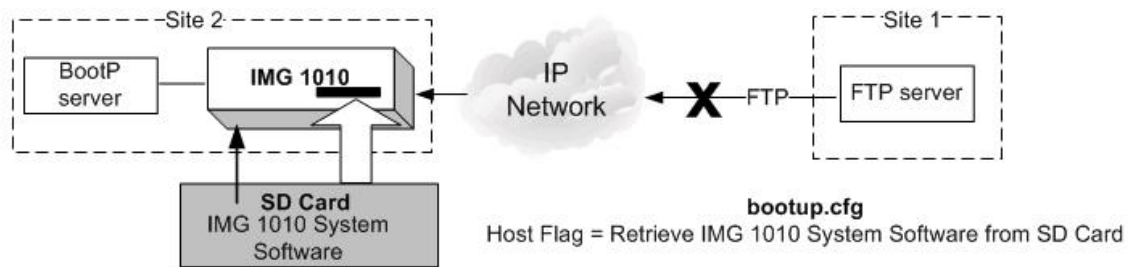

### Steps

1. Insert the SD Card into an SD Writer or use the [IMG 1010-SD Card Remote Provisioning](#) Feature.
2. Load the System Software File onto the SD Card.
3. On the SD Card provided with the IMG 1010 is a file named `bootup.cfg`.

4. Below is what the SD Card *bootup.cfg* information will look like.

```
#####
#####
# INSTRUCTIONS
#1. Edit values as required, as described below.
# Change IP Address, Subnet Mask, and Gateway IP Address to the actual #values for the
IMG.
# If you change the version of IMG System Software on the FTP Server #or the SD card,
make sure you change the System Software Filename #value.
# Make sure Host Flag is set appropriately for your configuration and #Boot method
#
# Calculate boot flag by adding values based on desired system attributes
# For a T1 system: add 0
# For an E1 system: add 2
#
# To boot from a FTP Server: add 0
# To boot from a SD Card: add 32
#
# For LBR codecs (512 ch/mod): add 0
# For LBR + ILBC codecs (336 ch/mod): add 16
# For LBR + ILBC + Wireless codecs (336 ch/mod): add 24
#
# An example host flag for a T1 system booting from the SD card with LBR + iLBC codecs
would = 48 (0+32+16)
# Change Server Address to the actual address of the FTP server.
# The Server Name is not used at this time.
#2. After editing this file: save file, remove SD card, insert SD card #in the IMG, power-up
the IMG.
# _____
# IMG bootup configuration file
# IP Address
yiaddr=192.168.3.103
# Subnet Mask
subnet mask=255.255.255.0
# Gateway Address
giaddr=192.168.3.10
# System Software Filename
file=img1010_ver1033123_id0101.bin
# Host Flag
host flag=0
# Server Address for File transfer and SNTP operation.
siaddr=192.168.1.100
# Server Name (Optional, not currently used)
sname=factorydefault
#####
#####
```

## SD Card

5. Any line beginning with the # symbol is a comment and is not processed by the IMG 1010. Below is the information the user will edit for use in the user's network
  - **yiaddr** --> IP Address of the IMG 1010 being loaded
  - **subnetmask** --> Subnet mask of the IMG 1010 being loaded
  - **giaddr** --> IP Address of the Gateway connected to the IMG 1010
  - **file** --> System Software Filename. If loading software from SD Card then this is the filename of the software being loaded. Load this file onto the SD Card.
  - **Host flag** --> The Host Flag informs the IMG 1010 of configuration details such as T1 or E1, Boot from SD card or Boot from FTP Server, and a few other configuration details. See Setting Host Flags.
  - **siaddr** --> IP Address of FTP server. Also used as an NTP server.
  - **sname** --> Optional (not currently used). Do not edit this, or problems may occur
6. Change the Host Flag to "Retrieve IMG Build from SD Card".
  - Host Flag Values
  - 32 = Boot from SD Card, T1 system
  - 34 = Boot from SD Card, E1 system

Example: The following is a T1 system booting from SD Card. Refer to the file Setting Host Flags to follow the example

```
Boot From SD card = 32
T1 system = add    +00
Host Flag Value = 32
```

The Host Flag for a T1 system booting from SD Card = 32

7. Edit the bootup.cfg file to reflect the new Host Flag value
8. Edit the System Software Filename in the *bootup.cfg* file to reflect the new software file being loaded. (Ex: img1010\_ver1033123\_0101.bin)
9. Edit the rest of the bootup.cfg file to reflect your network values.
10. Save the bootup.cfg file.
11. Remove the SD card from the SD Writer.
12. Insert the SD card into the SD slot on the Front Panel of the IMG 1010.
13. Power-up the IMG 1010. The fans on the IMG 1010 will run at full speed while diagnostics are running and software is being loaded
14. The LCD screen will show the following:
  - While software is loading to IMG 1010, the LCD screen will display the following  
**MAC: 00:20:1C:04:03:11 ID:0101**  
**SDC Loading**
  - After the software has loaded to IMG 1010, the LCD screen will display the following  
**MAC: 00:20:1C:04:03:11 ID:0101**  
**Load OK/Jumping to Load**
  - After software is done loading, the LCD screen will display the node info and the fans will slow to normal operation  
**Node Name: IMG1010**  
**Node ID: 255**
15. The loading of software and configuring of network information is now complete. The IMG 1010 is now ready to be configured.

## Distributing System Software Using an SD Card - IMG 1010

**Topic Location:** IMG 1010-Installation and Setup Guide > IMG 1010-SD Card

If you have one or more remote IMG 1010(s) that cannot obtain a System Software upgrade using FTP or BootP, you can transfer the file to multiple SD cards and distribute the SD cards to each remote site. The bootup.cfg file on each SD Card can be edited using either an SD card reader or, if working with software 10.5.0+, the Remote SD Card provisioning feature can be used.

For more information on remote provisioning of SD Card, see [IMG1010-SD Card Remote SD Card Provisioning](#).

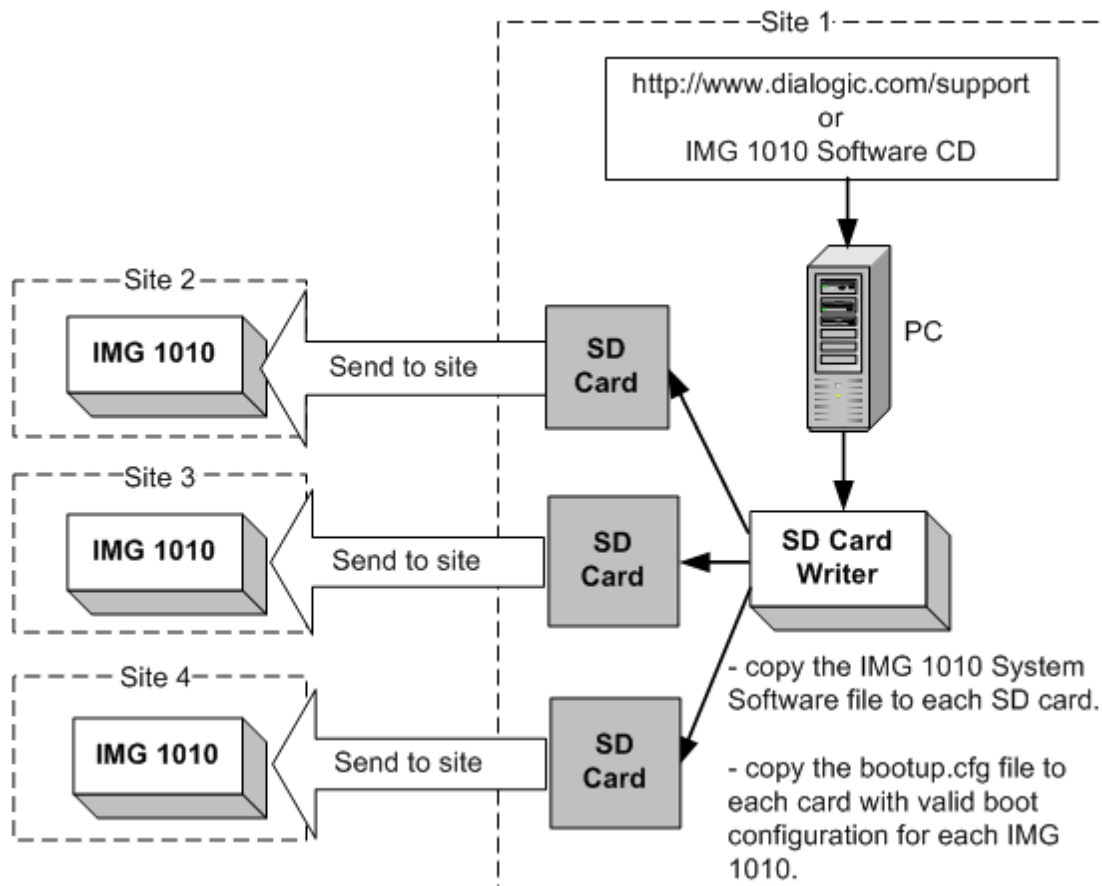

## Default bootup.cfg Configuration File - IMG 1010

**Topic Location:** IMG 1010-Installation and Setup Guide > IMG 1010-SD Card

```
# INSTRUCTIONS
#1. Edit values as required, as described below.
# Change IP Address, Subnet Mask, and Gateway IP Address to the actual
values for the IMG 1010.
# If you change the version of System Software on the FTP Server or the SD card,
# make sure you change the System Software Filename value.
# Make sure Host Flag is set appropriately for your configuration and Boot method

# Calculate Host Flag by adding values based on desired system attributes
# For a T1 system: add 0
# For an E1 system: add 2
#
# To boot from a FTP Server: add 0
# To boot from a SD Card: add 32
#
# For LBR codecs (512 ch/mod): add 0
# For LBR + ILBC codecs (336 ch/mod): add 16
# For LBR + ILBC + Wireless codecs (336 ch/mod): add 24
#
# An example host flag for a T1 system booting from the SD card with LBR + iLBC
codecs would = 48 (0+32+16)

# Change Server Address to the actual address of the FTP server.
# The Server Name is not used at this time.

#2. After editing this file: save file, remove SD card, insert SD card in the IMG 1010,
power-
#up the IMG 1010.

-----
# 1010 bootup configuration file
# IP Address
yiaddr=192.168.0.101

# Subnet Mask
subnet mask=255.255.255.0

# Gateway Address
giaddr=192.168.0.1

# System Software Filename
file=img1010_id0101.bin

# Host Flag
host flag=0x20

# Server Address for File transfer and Sntp operation.
siaddr=192.168.0.100

# Server Name (Optional, not currently used)
sname=factorydefault
```

## SD Card Remote Provisioning - IMG 1010

**Topic Location:** IMG 1010-Installation and Setup Guide > IMG 1010-SD Card

### Overview

This feature provides a means for installing new versions of system software to an IMG 1010 located at remote sites with no BOOTP server, by allowing remote access to the SD card on the IMG 1010. The SD Card is a small memory card like the memory cards used in digital cameras and other devices. The IMG 1010 has an SD card slot positioned on the right hand side of the front panel just below the USB port. Prior to software version 10.3.x, the only way to access and edit information on the SD Card would have been to physically go to the remote IMG 1010, pull the card out, insert it into an SD Reader, and edit the information on the SD Card. A new feature which has been implemented in software build 10.5.0, provisions the IMG 1010 as an FTP server instead of just an FTP client. This gives the user the ability to transfer files to and from the SD Card using the FTP utility. The FTP server functionality is disabled by default and would need to be enabled through ClientView in order for the remote provisioning to work.

### Related Topics:

[IMG 1010 - Downloading System Software Using a Boot File on an SD Card](#)

[IMG 1010 - Downloading System Software from an SD Card](#)

[IMG 1010 - Distributing System Software Using an SD Card](#)

[IMG 1010 - Default bootup.cfg File](#)

## Configuring Remote provisioning on SD card

**NOTE: To use the IMG 1010 as an FTP server, the SD Card must be inserted into the SD Card socket. The IMG 1010 will have system software running on it that was originally loaded through use of the SD Card**

1. Within ClientView, under the IMG Physical node, right click and select **New FTP Server**. Commit This. Below is a screen capture of the FTP Server Pane

FTP Server Disable		
Property	As-Configured	User-Specified
FTP Server		Disable
FTP Connection Status		
Remote IP Address		

2. In order to enable the IMG 1010 as an FTP server, select enable in the drop down menu in the "FTP Server" field.

FTP Server Disable		
Property	As-Configured	User-Specified
FTP Server		Disable ▾
FTP Connection Status		Enable
Remote IP Address		Disable

## SD Card

3. If an FTP session is connected to the IMG 1010 the "FTP Connection Status" field and the "Remote IP Address" field will update. See screen capture below. Notice the Remote IP address field. This is the IP address of the PC from which the user is FTP'ing.

FTP Server Enable		
Property	As-Configured	User-Specified
FTP Server	Enable	Enable
FTP Connection Status	Connected	
Remote IP Address	10.129.39.55	

4. At this point, files can be FTP'd to and from the IMG 1010. Below is an example of using FTP to change the version of software loaded on the SD card

### Procedure:

1. The following procedure explaining how one can change the load on an SD Card and upgrade the IMG 1010 software. The procedure will assume that:
  - An SD Card was previously used to load IMG 1010 software and the IMG 1010 is running with that software.
  - The FTP Server is configured and enabled in ClientView. See Steps 1-4 above

```
From a DOS or UNIX prompt
ftp <IP address of IMG 1010>
User: excelsw
Password: excelsw
ftp>
```

**NOTE: FTP Applications such as WinSCP that use SFTP (Secure FTP) or SCP (Secure Copy) will not connect to the IMG 1010. Only the FTP Protocol is supported for transferring the files to the IMG 1010 SD Card.**

2. Once logged in you can transfer the new updated IMG 1010 software file. Transfer this file as binary.

```
ftp> dir (dir command will show what is loaded on SD Card)
ftp> bin (Set mode to transfer file as binary)
ftp> hash (enable hash printing)
ftp> put img1010_<software version>_id0101.bin (Transfer times could vary from 2 to 10 minutes depending on server speed, memory size, etc.)
```

3. Verify that the software file was successfully transferred by using the dir or ls command.

```
ftp> dir
```

4. Transfer the bootup.cfg file from the IMG 1010 with the SD Card to the PC.

```
ftp> dir (dir command will show what is loaded on SD Card)
ftp> ascii (Set mode to transfer file as ascii)
ftp> get bootup.cfg (Get copy of bootup.cfg from SD Card)
```

5. Modify the "file=" line on the bootup.cfg file just transferred. Verify that changes to this file are correct. Below is the line in the bootup.cfg file that will need to be edited.

```
# System Software Filename
file=img1010_ver1050137_id0101.bin (Change ver1050137 to new
software build. Ex: ver1050140)
```

6. Before transferring the new bootup.cfg file to the SD Card, rename the existing file on the SD card. This can be accomplished using the rename command in FTP. See Below

```
ftp> rename bootup.cfg bootup_old.cfg
```

7. Transfer the new bootup.cfg file to the IMG 1010. Transfer this file as ASCII text.

```
ftp> ascii (Set to transfer an ascii text file)
ftp> put bootup.cfg (Transfer will take a few seconds)
```

8. Once the software is transferred, verify that both files were transferred successfully to the SD Card.
9. In order to load current software into the IMG 1010, the IMG 1010 must be rebooted. Go to ClientView and under the IMG 1010 Physical Node right click and select **Clear Software**.
10. A box will pop up informing you that "This option could have significant effects on the system. Are you sure you want to clear software". Select YES button.
11. The IMG 1010 will now reboot. If you are near the IMG 1010, you should see that the LCD on the front of the panel should display the following while the software is loading.

**MAC: 00:20:1C:04:03:11 ID:0101**  
**SDC Loading**

After the software has loaded to the IMG 1010, the LCD screen will display the following:

**MAC: 00:20:1C:04:03:11 ID:0101**  
**Load OK/Jumping to Load**

After the software is done loading, the LCD screen will display the node info and the fans will slow to normal operation.

**Node Name: IMG1010**  
**Node ID: 255**

12. The loading of software through the SD Card will take approximately 4 minutes. Once the software is loaded, the GCEMS will configure the IMG 1010.

## IMG 1004 - SD Card

### Downloading System Software Using Boot File on an SD Card - IMG 1004

**Topic Location:** IMG 1004-Installation and Setup Guide > IMG 1004-SD Card

A BootP server is used to configure the following:

- IMG CTRL IP address
- subnet mask
- gateway address
- FTP server address
- FTP file name of the IMG system software

If a BootP server is not available but a remote FTP Server is available, the SD card can be used to configure the boot parameters so the IMG 1004 can retrieve the system software from the remote FTP Server. See Diagram Below.

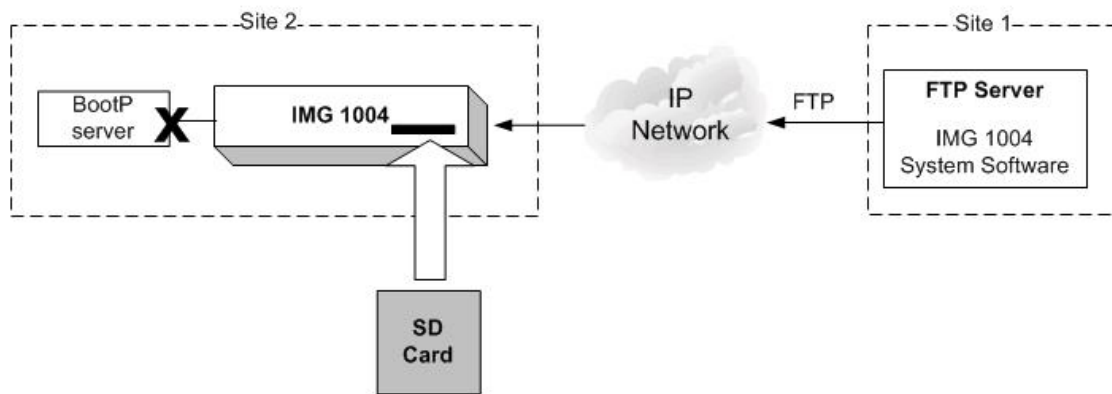

#### Bootup.cfg

Host Flag = Retrieve IMG 1004 System Software from FTP server  
Server Address = Your FTP Server address

### Steps

1. Insert the SD Card into an SD Writer connected to a PC.
2. On the SD Card is a file named bootup.cfg. Open this file.

## SD Card

3. Below is what the SD Card bootup.cfg information should look like.

```
#####  
#####  
# INSTRUCTIONS  
# 1. Edit values as required, as described below.  
# Change IP Address, Subnet Mask, and Gateway IP Address to the actual #values for the  
# IMG.  
# If you change the version of IMG System Software on the FTP Server #or the SD card,  
# make sure you change the System Software Filename #value.  
# Make sure Host Flag is set appropriately for your configuration and #Boot method  
#  
# Calculate boot flag by adding values based on desired system attributes  
# For a T1 system: add 0  
# For an E1 system: add 2  
#  
# To boot from a FTP Server: add 0  
# To boot from a SD Card: add 32  
#  
# For LBR codecs (512 ch/mod): add 0  
# For LBR + ILBC codecs (336 ch/mod): add 16  
# For LBR + ILBC + Wireless codecs (336 ch/mod): add 24  
#  
# An example host flag for a T1 system booting from the SD card with LBR + iLBC codecs  
# would = 48 (0+32+16)  
# Change Server Address to the actual address of the FTP server.  
# The Server Name is not used at this time.  
# 2. After editing this file: save file, remove SD card, insert SD card #in the IMG, power-up  
# the IMG.  
#-----  
# IMG bootup configuration file  
# IP Address  
yiaddr=192.168.3.103  
# Subnet Mask  
subnet mask=255.255.255.0  
# Gateway Address  
giaddr=192.168.3.10  
# System Software Filename  
file=/excelsw/ftpBuilds  
# Host Flag  
host flag=0  
# Server Address for File transfer and SNTP operation.  
siaddr=192.168.1.100  
# Server Name (Optional, not currently used)  
sname=factorydefault  
#####  
#####
```

4. Any line beginning with the # symbol is a comment and is not processed by the IMG 1004. Below is the information the user will edit for use in the users network

- **yiaddr** --> IP Address of the IMG 1004 being loaded
- **subnetmask** --> Subnet mask of the IMG 1004 being loaded
- **giaddr** --> IP Address of the Gateway connected to the IMG 1004
- **file** --> If using the SD card to supply boot information but loading the software from the FTP Server, the System Software Filename on the bootup.cfg file should be given a path to the IMG System Software file located on the ftp server. The default path is /excelsw/ftpBuilds or ftpBuilds/ as the IMG 1004 logs into the FTP server using the excelsw account.
- **Host flag** --> The Host Flag informs the IMG 1004 of configuration details such as T1 or E1, Boot from SD card or Boot from FTP Server, and a few other configuration details. See [Setting Host Flags](#).
- **siaddr** --> IP Address of FTP server which provides the IMG 1004 System Software and NTP Server information
- **sname** --> Optional, not currently used. Do not edit this

5. Change the Host Flag to "Retrieve IMG Build from SD Card".

Host Flag Values

32 = Boot from SD Card, T1 system

34 = Boot from SD Card, E1 system

**Example: The following is a T1 system booting from SD Card. Refer to the file [Setting Host Flags](#) to follow the example**

Boot From SD card = 32

T1 system = add +00

Host Flag Value = 32

The Host Flag for a T1 system booting from SD Card = 32

6. Edit the bootup.cfg file to reflect the new Host Flag value
7. Edit the System Software Filename in the bootup.cfg file to reflect the new software file being loaded. (Ex: file=/excelsw/ftpBuilds)
8. Edit the rest of the bootup.cfg file to reflect your network values.
9. Save the bootup.cfg file
10. Remove the SD card from the SD Writer.
11. Insert the SD card into the SD slot on the Front Panel of the IMG 1004.
12. Power-up the IMG 1004.
13. The IMG 1004 will go through a diagnostic check and then load software. See [IMG 1004 - Front Panel Status LED\(s\)](#) for more information on the boot process.
14. Once the loading of software and configuring of network information is complete, the IMG 1004 will be ready to get configured.

## Downloading System Software From an SD Card - IMG 1004

**Topic Location:** IMG 1004-Installation and Setup Guide > IMG 1004-SD Card

If the IMG 1004 does not have access to an FTP server, then the IMG 1004 System Software and IP information can be loaded through the use of an SD Card. The SD Card is a small memory card like the memory cards used in digital cameras and other devices. The IMG 1004 has an SD card slot positioned on the right hand side of the front panel just below the USB port. The SD card holds the `bootup.cfg` file and the IMG 1004 System Software file. The procedure below will explain how one can load the IMG 1004 System Software and IP addresses using just the SD Card.

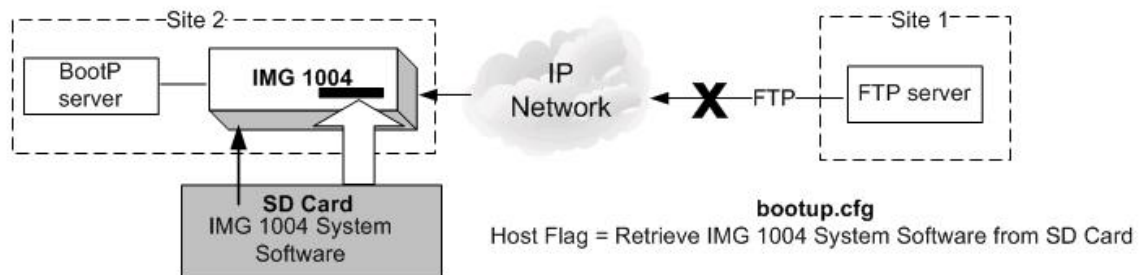

### Steps

1. Insert the SD Card into an SD Writer.
2. Load the System Software File onto the SD Card or use the [IMG 1004 - SD Card Remote Provisioning](#) Feature.
3. On the SD Card provided with the IMG 1004 is a file named `bootup.cfg`.

4. Below is what the SD Card *bootup.cfg* information will look like.

```
#####
#####
# INSTRUCTIONS
# 1. Edit values as required, as described below.
# Change IP Address, Subnet Mask, and Gateway IP Address to the actual #values for the
IMG.
# If you change the version of IMG System Software on the FTP Server #or the SD card,
make sure you change the System Software Filename #value.
# Make sure Host Flag is set appropriately for your configuration and #Boot method
#
# Calculate boot flag by adding values based on desired system attributes
# For a T1 system: add 0
# For an E1 system: add 2
#
# To boot from a FTP Server: add 0
# To boot from a SD Card: add 32
#
# For LBR codecs (512 ch/mod): add 0
# For LBR + ILBC codecs (336 ch/mod): add 16
# For LBR + ILBC + Wireless codecs (336 ch/mod): add 24
#
# An example host flag for a T1 system booting from the SD card with LBR + iLBC codecs
would = 48 (0+32+16)
# Change Server Address to the actual address of the FTP server.
# The Server Name is not used at this time.
# 2. After editing this file: save file, remove SD card, insert SD card #in the IMG, power-up
the IMG.
# _____
# IMG bootup configuration file
# IP Address
yiaddr=192.168.3.103
# Subnet Mask
subnet mask=255.255.255.0
# Gateway Address
giaddr=192.168.3.10
# System Software Filename
file=img1004_ver1050123_id0106.bin
# Host Flag
host flag=0
# Server Address for File transfer and SNTP operation.
siaddr=192.168.1.100
# Server Name (Optional, not currently used)
sname=factorydefault
#####
=====
```

## SD Card

5. Any line beginning with the # symbol is a comment and is not processed by the IMG 1004. Below is the information the user will edit for use in the user's network
  - **yiaddr** --> IP Address of the IMG 1004 being loaded
  - **subnetmask** --> Subnet mask of the IMG 1004 being loaded
  - **giaddr** --> IP Address of the Gateway connected to the IMG 1004
  - **file** --> System Software Filename. If loading software from SD Card then this is the filename of the software being loaded. Load this file onto the SD Card.
  - **Host flag** --> The Host Flag informs the IMG 1004 of configuration details such as T1 or E1, Boot from SD card or Boot from FTP Server, and other configuration details. See Setting Host Flags.
  - **siaddr** --> IP Address of FTP server. Also used as an NTP server.
  - **sname** --> Optional (not currently used). Do not edit this, or problems may occur
6. Change the Host Flag to "Retrieve IMG Build from SD Card".

### Host Flag Values

32 = Boot from SD Card, T1 system  
34 = Boot from SD Card, E1 system

Example: The following is a T1 system booting from SD Card. Refer to the file Setting Host Flags to follow the example

```
Boot From SD card = 32
T1 system = add    +00
Host Flag Value = 32
```

The Host Flag for a T1 system booting from SD Card = 32

7. Edit the `bootup.cfg` file to reflect the new Host Flag value
8. Edit the System Software Filename in the `bootup.cfg` file to reflect the new software file being loaded. (Ex: `img1004_ver1050123_0106.bin`)
9. Edit the rest of the `bootup.cfg` file to reflect your network values.
10. Save the `bootup.cfg` file.
11. Remove the SD card from the SD Writer.
12. Insert the SD card into the SD slot on the Front Panel of the IMG 1004.
13. Power-up the IMG 1004.
14. The IMG 1004 will go through a diagnostic check and then load software. See Front Panel Status LEDs 1004 for more information on the boot process.
15. Once the loading of software and configuring of network information is complete, the IMG 1004 will be ready to get configured.

## Distributing System Software Using an SD Card - IMG 1004

**Topic Location:** IMG 1004-Installation and Setup Guide > IMG 1004-SD Card

If you have one or more remote IMG 1004(s) that cannot obtain a System Software upgrade using FTP or BootP, you can transfer the file to multiple SD cards and distribute the SD cards to each remote site. The bootup.cfg file on each SD Card can be edited using either an SD card reader or if working with software 10.5.0+, the Remote SD Card provisioning feature can be used.

For more information on remote provisioning of SD Card, see [IMG1004-SD Card Remote Provisioning](#).

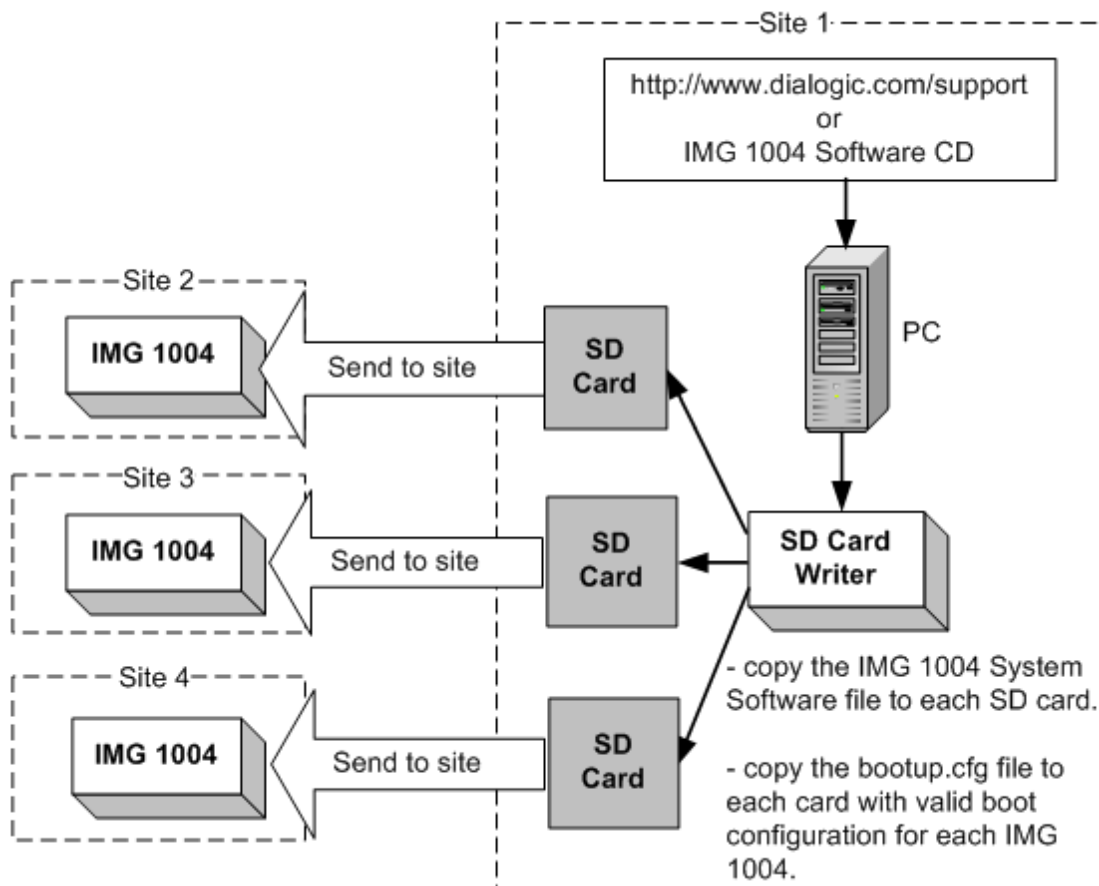

## Default bootup.cfg Configuration File - IMG 1004

**Topic Location:** IMG 1004-Installation and Setup Guide > IMG 1004-SD Card

# INSTRUCTIONS

#1. Edit values as required, as described below.

# Change **IP Address**, **Subnet Mask**, and **Gateway IP Address** to the actual values for the IMG 1004.

# If you change the version of IMG System Software on the FTP Server or the SD card, #make sure you change the **System Software Filename** value.

# Make sure **Host Flag** is set appropriately for your configuration and Boot method

    # Calculate **Host Flag** by adding values based on desired system attributes

    # For a T1 system: add 0

    # For an E1 system: add 2

    #

    # To boot from a FTP Server: add 0

    # To boot from a SD Card: add 32

    #

    # For LBR codecs (512 ch/mod): add 0

    # For LBR + ILBC codecs (336 ch/mod): add 16

    # For LBR + ILBC + Wireless codecs (336 ch/mod): add 24

    #

    # An example host flag for a T1 system booting from the SD card with LBR +  
    iLBC codecs would = 48 (0+32+16)

# Change **Server Address** to the actual address of the FTP server.

# The **Server Name** is not used at this time.

#2. After editing this file: save file, remove SD card, insert SD card in the IMG,  
power-#up the IMG.

---

# IMG 1004 bootup configuration file

# IP Address

yiaddr=192.168.0.101

# Subnet Mask

subnet mask=255.255.255.0

# Gateway Address

giaddr=192.168.0.1

# System Software Filename

file=img1004\_id0106.bin

# Host Flag

host flag=0x20

# Server Address for File transfer and Sntp operation.

siaddr=192.168.0.100

# Server Name (Optional, not currently used)

sname=factorydefault

## SD Card Remote Provisioning - IMG 1004

**Topic Location:** IMG 1004-Installation and Setup Guide > IMG 1004-SD Card

### Overview

This feature provides a means for installing new versions of system software to an IMG 1004 located at remote sites with no BOOTP server, by allowing remote access to the SD card on the IMG 1004. The SD Card is a small memory card much like the memory cards used in digital cameras and other devices. The IMG 1004 has an SD card slot positioned on the right hand side of the front panel just below the USB port. Prior to software version 10.3.x, the only way to access and edit information on the SD Card would have been to physically go to the remote IMG 1004, pull the card out, insert it into an SD Reader, and edit the information on the SD Card. A new feature which has been implemented in software build 10.5.0 provisions the IMG 1004 as an FTP server instead of just an FTP client. This gives the user the ability to transfer files to and from the SD Card using the FTP utility. The FTP server functionality is disabled by default and would need to be enabled through ClientView in order for the remote provisioning to work.

### Related Topics:

[IMG 1004 - Downloading System Software Using a Boot File on an SD Card](#)

[IMG 1004 - Downloading System Software from an SD Card](#)

[IMG 1004 - Distributing System Software Using an SD Card](#)

[IMG 1004 - Default bootup.cfg File](#)

## Configuring Remote provisioning on SD card

**NOTE: To use the IMG 1004 as an FTP server the SD Card must be inserted into the SD Card socket. The IMG 1004 will have system software running on it which was originally loaded through use of the SD Card**

1. Within ClientView, under the IMG 1004 Physical node, right click and select **New FTP Server**. Commit This. Below is a screen capture of the FTP Server Pane

FTP Server Disable		
Property	As-Configured	User-Specified
FTP Server		Disable
FTP Connection Status		
Remote IP Address		

2. In order to enable the IMG 1004 as an FTP server, select enable in the drop down menu in the "FTP Server" field.

FTP Server Disable		
Property	As-Configured	User-Specified
FTP Server		Enable
FTP Connection Status		Enable
Remote IP Address		Disable

## SD Card

3. If someone has FTP'd to the IMG 1004, the "FTP Connection Status" field and the "Remote IP Address" field will update. See screen capture below. Notice the Remote IP address field. This is the IP address of the PC from which the user is FTP'ing.

FTP Server Enable		
Property	As-Configured	User-Specified
FTP Server	Enable	Enable
FTP Connection Status	Connected	
Remote IP Address	10.129.39.55	

4. At this point, files can be FTP'd to and from the IMG 1004. Below is an example of using FTP to change the version of software loaded on the SD card

### Procedure:

1. The following procedure will explain how one can change the load on an SD Card and upgrade the IMG 1004 software. The procedure will assume that:
  - An SD Card was previously used to load IMG 1004 software and the IMG 1004 is running with that software.
  - The FTP Server is configured and enabled in ClientView. See Steps 1-4 above

```
From a DOS or UNIX prompt
ftp <IP address of IMG1004>
User: excelsw
Password: excelsw
ftp>
```

**NOTE: FTP Applications such as WinSCP that use SFTP (Secure FTP) or SCP (Secure Copy) will not connect to the IMG 1004. Only the FTP Protocol is supported for transferring the files to the IMG 1004 SD Card.**

2. Once logged in, you can transfer the new updated IMG 1004 software file. Transfer this file as binary.

```
ftp> dir (dir command will show what is loaded on SD Card)
ftp> bin (Set mode to transfer file as binary)
ftp> hash (enable hash printing)
ftp> put img1004_<software version>_id0106.bin (Transfer times could vary from 2 to 10 minutes depending on such factors as server speed, memory size, etc.)
```

3. Verify that the software file was successfully transferred by using the dir or ls command.

```
ftp> dir
```

4. Transfer the bootup.cfg file from the IMG 1004 with the SD Card to the PC.

```
ftp> dir (dir command will show what is loaded on SD Card)
ftp> ascii (Set mode to transfer file as ascii)
ftp> get bootup.cfg (Get copy of bootup.cfg from SD Card)
```

5. Modify the "file=" line on the bootup.cfg file just transferred. Verify that the changes to this file are correct. Below is the line in the bootup.cfg file that will need to be edited.

```
# System Software Filename
file=img1004_ver1050137_id0106.bin (Change ver1050137 to new
software build. Ex: ver1050140)
```

6. Before transferring the new bootup.cfg file to the SD, rename the existing file on the SD card. This can be accomplished using the rename command in FTP. See Below

```
ftp> rename bootup.cfg bootup_old.cfg
```

7. Transfer the new bootup.cfg file to the IMG 1004. Transfer this file as ASCII text.

```
ftp> ascii (Set to transfer an ascii text file)
ftp> put bootup.cfg (Transfer will take a few seconds)
```

8. Once the software is transferred, verify that both files were transferred successfully to the SD Card.
9. In order to load latest software the IMG 1004 must be rebooted. Go to ClientView and under the IMG 1004 Physical Node right click and select **Clear Software**.
10. A box will pop up informing you that "This option could have significant effects on the system. Are you sure you want to clear software" Select YES button.
11. The IMG 1004 will now reboot and eventually Software will start loading. Refer to the topic IMG 1004-Hardware Reference > IMG 1004-Front Panel > IMG 1004 - Front Panel Status LEDs in the online documentation for information on LED sequencing and error codes that might occur during the bootup process.
12. The loading of software through the SD Card will take approximately 4 minutes. Once software is loaded then GCEMS will configure the IMG 1004.