



# Dialogic® Hardware Connectivity Manual

## Copyright and legal notices

---

Copyright © 2009-2010 Dialogic Corporation. All Rights Reserved. You may not reproduce this document in whole or in part without permission in writing from Dialogic Corporation at the address provided below.

All contents of this document are furnished for informational use only and are subject to change without notice and do not represent a commitment on the part of Dialogic Corporation or its subsidiaries ("Dialogic"). Reasonable effort is made to ensure the accuracy of the information contained in the document. However, Dialogic does not warrant the accuracy of this information and cannot accept responsibility for errors, inaccuracies or omissions that may be contained in this document.

INFORMATION IN THIS DOCUMENT IS PROVIDED IN CONNECTION WITH DIALOGIC® PRODUCTS. NO LICENSE, EXPRESS OR IMPLIED, BY ESTOPPEL OR OTHERWISE, TO ANY INTELLECTUAL PROPERTY RIGHTS IS GRANTED BY THIS DOCUMENT. EXCEPT AS PROVIDED IN A SIGNED AGREEMENT BETWEEN YOU AND DIALOGIC, DIALOGIC ASSUMES NO LIABILITY WHATSOEVER, AND DIALOGIC DISCLAIMS ANY EXPRESS OR IMPLIED WARRANTY, RELATING TO SALE AND/OR USE OF DIALOGIC PRODUCTS INCLUDING LIABILITY OR WARRANTIES RELATING TO FITNESS FOR A PARTICULAR PURPOSE, MERCHANTABILITY, OR INFRINGEMENT OF ANY INTELLECTUAL PROPERTY RIGHT OF A THIRD PARTY.

Dialogic products are not intended for use in medical, life saving, life sustaining, critical control or safety systems, or in nuclear facility applications.

Due to differing national regulations and approval requirements, certain Dialogic products may be suitable for use only in specific countries, and thus may not function properly in other countries. You are responsible for ensuring that your use of such products occurs only in the countries where such use is suitable. For information on specific products, contact Dialogic Corporation at the address indicated below or on the web at [www.dialogic.com](http://www.dialogic.com).

It is possible that the use or implementation of any one of the concepts, applications, or ideas described in this document, in marketing collateral produced by or on web pages maintained by Dialogic may infringe one or more patents or other intellectual property rights owned by third parties. Dialogic does not provide any intellectual property licenses with the sale of Dialogic products other than a license to use such product in accordance with intellectual property owned or validly licensed by Dialogic and no such licenses are provided except pursuant to a signed agreement with Dialogic. More detailed information about such intellectual property is available from Dialogic's legal department at 9800 Cavendish Blvd., 5th Floor, Montreal, Quebec, Canada H4M 2V9. Dialogic encourages all users of its products to procure all necessary intellectual property licenses required to implement any concepts or applications and does not condone or encourage any intellectual property infringement and disclaims any responsibility related thereto. These intellectual property licenses may differ from country to country and it is the responsibility of those who develop the concepts or applications to be aware of and comply with different national license requirements.

Dialogic, Dialogic Pro, Brooktrout, Diva, Cantata, SnowShore, Eicon, Eicon Networks, NMS Communications, NMS (stylized), Eiconcard, SIPcontrol, Diva ISDN, TruFax, Exnet, EXS, SwitchKit, N20, Making Innovation Thrive, Connecting to Growth, Video is the New Voice, Fusion, Vision, PacketMedia, NaturalAccess, NaturalCallControl, NaturalConference, NaturalFax and Shiva, among others as well as related logos, are either registered trademarks or trademarks of Dialogic Corporation or its subsidiaries. Dialogic's trademarks may be used publicly only with permission from Dialogic. Such permission may only be

granted by Dialogic's legal department at 9800 Cavendish Blvd., 5th Floor, Montreal, Quebec, Canada H4M 2V9. Any authorized use of Dialogic's trademarks will be subject to full respect of the trademark guidelines published by Dialogic from time to time and any use of Dialogic's trademarks requires proper acknowledgement.

The names of actual companies and products mentioned herein are the trademarks of their respective owners.

This document discusses one or more open source products, systems and/or releases. Dialogic is not responsible for your decision to use open source in connection with Dialogic products (including without limitation those referred to herein), nor is Dialogic responsible for any present or future effects such usage might have, including without limitation effects on your products, your business, or your intellectual property rights.

Using the AMR-NB resource in connection with one or more Dialogic products mentioned herein does not grant the right to practice the AMR-NB standard. To seek a patent license agreement to practice the standard, contact the VoiceAge Corporation at <http://www.voiceage.com/licensing.php>.

## Revision history

---

Revision	Release date	Notes
64-0514-01	October 2009	LBG, NaturalAccess R9.0
64-0514-02 Rev A	October 2010	LBG, NaturalAccess R9.0.4
Last modified: 2010-10-15		

Refer to [www.dialogic.com](http://www.dialogic.com) for product updates and for information about support policies, warranty information, and service offerings.

# Table Of Contents

---

<b>1. Introduction.....</b>	<b>1</b>
<b>2. Glossary of terms.....</b>	<b>5</b>
<b>3. Interfaces and connectors .....</b>	<b>6</b>
RJ-45 Ethernet connectors.....	6
RJ-48C interface.....	6
Pin assignments .....	6
Dialogic® MD1 RJ-45 interface.....	7
Pin assignments .....	7
Dialogic® MD1 RJ-21 interface.....	8
Pin assignments .....	8
Dialogic® MD1 Mini RJ-21 interface .....	9
Pin assignments .....	9
Interfaces by board type .....	10
<b>4. Dialogic cables .....</b>	<b>12</b>
Overview of cables .....	12
Dual T1/E1 120 ohm adapter cable.....	13
Pin assignments .....	13
Dialogic® MD1 RJ-45 to MD1 RJ-45 cable.....	14
Pin assignments .....	14
RJ-48C to RJ-48C single crossover cable .....	15
Pin assignments .....	15
Dialogic® MD1 RJ-21 male to MD1 RJ-21 cable.....	16
Pin assignments .....	16
Dialogic® MD1 Mini RJ-21 to MD1 RJ-21 cable .....	17
Pin assignments .....	17
RJ-48C to BNC splitter cable .....	19
Dialogic® MD1 RJ-45 to two BNC pairs splitter cable .....	20
<b>5. Dialogic signal entry panel.....</b>	<b>21</b>
Overview of Dialogic® signal entry panel .....	21
Dimensions.....	21
Schematic.....	22
Cabling the signal entry panel.....	23
Cabling boards with Dialogic® MD1 RJ-21 interfaces.....	23
Cabling boards with Dialogic® MD1 Mini RJ-21 interfaces .....	23
Signal entry panel kits.....	24
<b>6. Miscellaneous components and certifications .....</b>	<b>25</b>
RJ-48C to 75 ohm BNC connector pair transformer .....	25
Punchdown block.....	26
Schematic.....	27
Compliance and regulatory certification .....	28
Safety .....	28
<b>Index .....</b>	<b>29</b>

# 1. Introduction

---

The *Dialogic® Hardware Connectivity Manual* is written for those who plan and install solutions that contain CG Series Media Boards, TX Series SS7 Boards, and the Vision™ Family of Servers and Gateways.

This manual provides detailed information about connectors and connector pin assignments (interfaces) on Dialogic products, and defines the Dialogic signal entry panel (SEP) solutions used to convert products with Dialogic® MD1 RJ-21 interface and Dialogic® MD1 Mini RJ-21 interfaces to industry-standard RJ-48C Telco interfaces.

**Warning:**



**Important safety notes for telephony connections**

- Allow only qualified technical personnel to install NMS hardware and its associated telephone wiring.
- Make sure the PC chassis is grounded through the power cord or by other means before connecting the telephone line.
- If your system requires an external power supply, make sure it is grounded through the power cord or by other means.
- Never install telephone wiring during a lightning storm.
- Never install telephone jacks in wet locations.
- Telephone companies provide primary lightning protection for their telephone lines. However, if a site connects to private lines that leave the building, make sure that external protection is provided.

## Terminology

---

**Note:** The product to which this document pertains is part of the NMS Communications Platforms business that was sold by NMS Communications Corporation (“NMS”) to Dialogic Corporation (“Dialogic”) on December 8, 2008. Accordingly, certain terminology relating to the product has been changed. Below is a table indicating both terminology that was formerly associated with the product, as well as the new terminology by which the product is now known. This document is being published during a transition period; therefore, it may be that some of the former terminology will appear within the document, in which case the former terminology should be equated to the new terminology, and vice versa.

Former terminology	Dialogic terminology
CG 6060 Board	Dialogic® CG 6060 PCI Media Board
CG 6060C Board	Dialogic® CG 6060C CompactPCI Media Board
CG 6565 Board	Dialogic® CG 6565 PCI Media Board
CG 6565C Board	Dialogic® CG 6565C CompactPCI Media Board
CG 6565e Board	Dialogic® CG 6565E PCI Express Media Board
CX 2000 Board	Dialogic® CX 2000 PCI Station Interface Board
CX 2000C Board	Dialogic® CX 2000C CompactPCI Station Interface Board
AG 2000 Board	Dialogic® AG 2000 PCI Media Board
AG 2000C Board	Dialogic® AG 2000C CompactPCI Media Board
AG 2000-BRI Board	Dialogic® AG 2000-BRI Media Board
NMS OAM Service	Dialogic® NaturalAccess™ OAM API
NMS OAM System	Dialogic® NaturalAccess™ OAM System
NMS SNMP	Dialogic® NaturalAccess™ SNMP API
Natural Access	Dialogic® NaturalAccess™ Software
Natural Access Service	Dialogic® NaturalAccess™ Service
Fusion	Dialogic® NaturalAccess™ Fusion™ VoIP API
ADI Service	Dialogic® NaturalAccess™ Alliance Device Interface API

Former terminology	Dialogic terminology
CDI Service	Dialogic® NaturalAccess™ CX Device Interface API
Digital Trunk Monitor Service	Dialogic® NaturalAccess™ Digital Trunk Monitoring API
MSPP Service	Dialogic® NaturalAccess™ Media Stream Protocol Processing API
Natural Call Control Service	Dialogic® NaturalAccess™ NaturalCallControl™ API
NMS GR303 and V5 Libraries	Dialogic® NaturalAccess™ GR303 and V5 Libraries
Point-to-Point Switching Service	Dialogic® NaturalAccess™ Point-to-Point Switching API
Switching Service	Dialogic® NaturalAccess™ Switching Interface API
Voice Message Service	Dialogic® NaturalAccess™ Voice Control Element API
NMS CAS for Natural Call Control	Dialogic® NaturalAccess™ CAS API
NMS ISDN	Dialogic® NaturalAccess™ ISDN API
NMS ISDN for Natural Call Control	Dialogic® NaturalAccess™ ISDN API
NMS ISDN Messaging API	Dialogic® NaturalAccess™ ISDN Messaging API
NMS ISDN Supplementary Services	Dialogic® NaturalAccess™ ISDN API Supplementary Services
NMS ISDN Management API	Dialogic® NaturalAccess™ ISDN Management API
NaturalConference Service	Dialogic® NaturalAccess™ NaturalConference™ API
NaturalFax	Dialogic® NaturalAccess™ NaturalFax™ API
SAI Service	Dialogic® NaturalAccess™ Universal Speech Access API
NMS SIP for Natural Call Control	Dialogic® NaturalAccess™ SIP API
NMS RJ-45 interface	Dialogic® MD1 RJ-45 interface
NMS RJ-21 interface	Dialogic® MD1 RJ-21 interface

Former terminology	Dialogic terminology
NMS Mini RJ-21 interface	Dialogic® MD1 Mini RJ-21 interface
NMS Mini RJ-21 to NMS RJ-21 cable	Dialogic® MD1 Mini RJ-21 to MD1 RJ-21 cable
NMS RJ-45 to two 75 ohm BNC splitter cable	Dialogic® MD1 RJ-45 to two 75 ohm BNC splitter cable
NMS signal entry panel	Dialogic® Signal Entry Panel
Video Access Utilities	Dialogic® NaturalAccess™ Video Access Toolkit Utilities
Video Mail Application Demonstration Program	Dialogic® NaturalAccess™ Video Access Toolkit Video Mail Application Demonstration Program
Video Messaging Server Interface	Dialogic® NaturalAccess™ Video Access Toolkit Video Messaging Server Interface
3G-324M Interface	Dialogic® NaturalAccess™ Video Access Toolkit 3G-324M Interface

## 2. Glossary of terms

---

The following table describes the terms used in this manual:

Term	Definition
MD1	Multiple DS1.
Mini RJ-21 connector	A high density 50-pin Telco connector.
Dialogic® MD1 Mini RJ-21 interface	A Mini RJ-21 connector with a pinout specified by Dialogic to have eight 4-wire T1/E1 connections.
RJ-21 connector	Physically, a 50-pin connector. Also referred to as a 50-pin Telco connector.
Dialogic® MD1 RJ-21 interface	An RJ-21 connector with a pinout specified by Dialogic to have eight 4-wire T1/E1 connections.
RJ-45 connector	A telephone connector that holds up to eight wires.
Dialogic® MD1 RJ-45 interface	An RJ-45 connector with a pinout specified by Dialogic to have two 4-wire T1/E1 connections.
RJ-48C interface	An RJ-45 connector with a pinout specified by ANSI to have a single 4-wire T1/E1 connection.
Connector	A physical device for making electrical connections.
Interface	A connector with a defined wiring pattern or specification.

### 3. Interfaces and connectors

#### RJ-45 Ethernet connectors

RJ-45 Ethernet connectors use the following pin assignments:

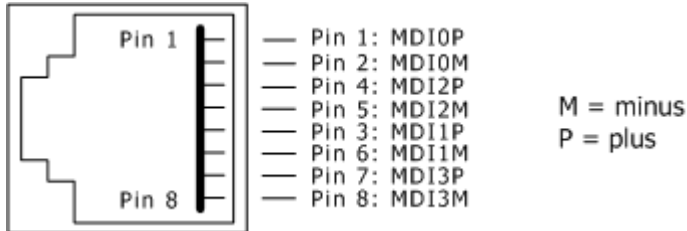

#### RJ-48C interface

An RJ-48C interface is an RJ-45 connector with pin assignments specified by ANSI to have a single 4-wire T1/E1 connection.

RJ-48C interfaces use the following pin assignments:

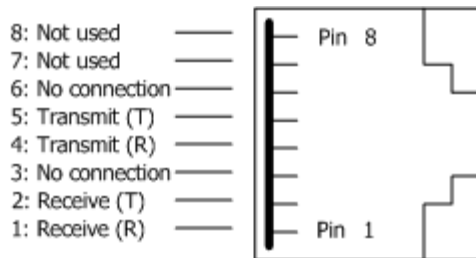

#### Pin assignments

The RJ-48C interface uses the following pin assignments:

Pin	Description
1	Receive from network (ring).
2	Receive from network (tip).
3	No connection.
4	Transmit to network (ring).
5	Transmit to network (tip).
6	No connection.
7	Optional shield, not used.
8	Optional shield, not used.

## Dialogic® MD1 RJ-45 interface

A Dialogic® MD1 RJ-45 interface uses the same connector as an RJ-48C but it has supplemental connections. An RJ-48C interface is commonly used for T1 lines and uses pins 1, 2, 4, and 5. A Dialogic® MD1 RJ-45 interface uses all eight pins.

Pin 8: Receive from network – R2  
 Pin 7: Receive from network – T2  
 Pin 6: Transmit to network – R2  
 Pin 5: Transmit to network – T1  
 Pin 4: Transmit to network – R1  
 Pin 3: Transmit to network – T2  
 Pin 2: Receive from network – T1  
 Pin 1: Receive from network – R1

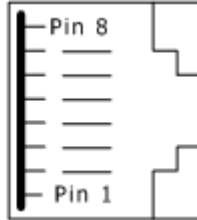

### Pin assignments

The Dialogic® MD1 RJ-45 interface uses the following pin assignments:

Pin	Description	Trunk
1	Receive from network (ring)	1
2	Receive from network (tip)	1
3	Transmit to network (tip)	2
4	Transmit to network (ring)	1
5	Transmit to network (tip)	1
6	Transmit to network (ring)	2
7	Receive from network (tip)	2
8	Receive from network (ring)	2

## Dialogic® MD1 RJ-21 interface

The following illustration shows a Dialogic® MD1 RJ-21 male interface:

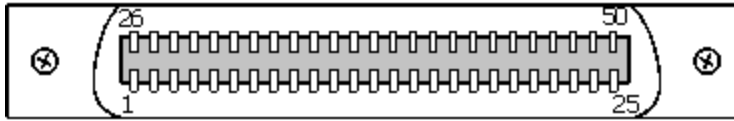

Dialogic® MD1 RJ-21 interface

### Pin assignments

The Dialogic® MD1 RJ-21 interface uses the following pin assignments:

Trunk	Transmit to network pin assignments		Receive from network pin assignments	
	Ring	Tip	Ring	Tip
1 and 9	1	26	2	27
2 and 10	3	28	4	29
3 and 11	5	30	6	31
4 and 12	7	32	8	33
5 and 13	9	34	10	35
6 and 14	11	36	12	37
7 and 15	13	38	14	39
8 and 16	15	40	16	41
Not used	17 through 25 42 through 50			

## Diallogic® MD1 Mini RJ-21 interface

A Diallogic® MD1 Mini RJ-21 interface is a high-density, modular interface that provides up to 12 RJ-45 ports through a single cable. The following illustration shows the Diallogic® MD1 Mini RJ-21 interface:

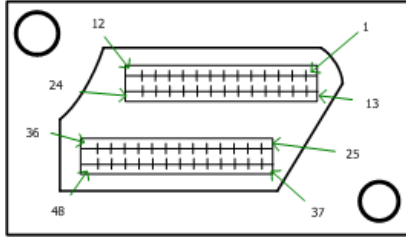



### Pin assignments



Diallogic® MD1 Mini RJ-21 interfaces use the following pin assignments:

Trunks	Transmit to network pin assignments		Receive from network pin assignments	
	Tip	Ring	Tip	Ring
1	1	2	13	14
2	3	4	15	16
3	25	26	37	38
4	27	28	39	40
5	5	6	17	18
6	7	8	19	20
7	29	30	41	42
8	31	32	43	44
Not used	9 and 10 21 and 22 11 and 12 23 and 24 33 and 34 45 and 46 35 and 36 47 and 48 49 and 50			

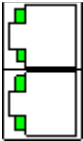
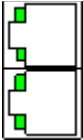
## Interfaces by board type

The following table provides an example of the interfaces used by the various Dialogic boards and servers:

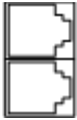
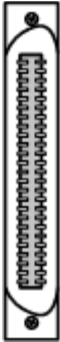
Interface example	Interface	Board name
	RJ-45 Ethernet 10/100Base-T	CG 6060 CG 6060C TX 4000 TX 4000/20 TX 4000C TX 4000C/20 TX 5500E (for Ethernet redundancy) TX 5020E (for Ethernet redundancy)
	RJ-45 Ethernet 10/100/1000Base-T	CG 6565 CG 6565C (does not apply to PICMG 2.16 versions) CG 6565E TX 5500E (for IP/SIGTRAN) TX 5020E (for IP/SIGTRAN)
	RJ-48C	CG 6060 1 T/E CG 6060 2 T/E CG 6060C 4 T/E CG 6060C 8 T/E (not all variants) CG 6565E 1 T/E CG 6565E 2 T/E

Interface example	Interface	Board name
	Dialogic® MD1 RJ-45 interface	CG 6060 4 T/E CG 6565 4 T/E CG 6565E 4 T/E TX 4000 TX 4000/20 TX 5500E TX 5020E Vision VoiceXML Server (VX 5000-8) Vision Media Gateway (VG-2000-4) Vision Signaling Server (TIGI2U)
	Dialogic® MD1 RJ-21	CG 6060C 8 T/E (not all variants) CG 6060C 16 T/E CG 6565C 8 T/E CG 6565C 16 T/E MG 7000A 16 T/E TX 4000C TX 4000/20C
	Dialogic® MD1 Mini RJ-21 interface	CG 6565 8 T/E CG 6565E 8 T/E Vision Media Gateway (VG 2000-8)

## 4. Dialogic cables

---

### Overview of cables

The following table lists the cables available from Dialogic:

Cable	Part number
Dialogic® MD1 RJ-45 to MD1 RJ-45 straight cable (36") (91 cm)	83233
Dialogic® MD1 RJ-45 to MD1 RJ-45 straight cable (42") (1.1m)	83224
Dialogic® MD1 RJ-45 to MD1 J-45 straight cable (72") (1.8m)	83235
Dialogic® MD1 RJ-45 to MD1 RJ-45 double crossover cable (36") (91 cm)	83188
Dialogic® MD1 RJ-45 to MD1 RJ-45 double crossover cable (50") (1.3m)	83227
Dialogic® MD1 RJ-45 to RJ-48C pair splitter cable, 120-ohm, 4" (10 cm)	83230
RJ-48C to RJ-48C single crossover cable (36") (91 cm)	83231
Dialogic® MD1 RJ-45 to two BNC pairs splitter cable (9") (23 cm)	83232
Dialogic® MD1 RJ-21 to MD1 RJ-21 straight cable (72") (1.8 m)	83225
Dialogic® MD1 RJ-21 to MD1 RJ-21 right angle cable (72") (1.8 m)	83228
Dialogic® MD1 Mini RJ-21 to MD1 RJ-21 cable (72") (1.8m)	83226
RJ-48C to BNC pair splitter cable (9") (23 cm)	83229

## Dual T1/E1 120 ohm adapter cable

The dual T1/E1 120 ohm adapter cable (P/N 83230) divides 8-pin shielded modular Dialogic® MD1 RJ-45 interfaces into two shielded modular RJ-48C interfaces.

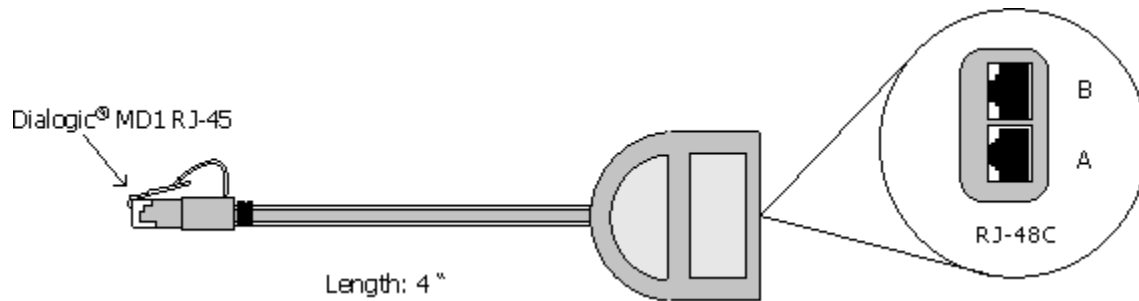

### Pin assignments

Dual T1/E1 120 ohm adapter cables use the following pin assignments:

Dialogic® MD1 RJ-45 plug	RJ-48C (A)	RJ-48C (B)
1: RxR1	1	
2: RxT1	2	
3: TxT2		5
4: TxR1	4	
5: TxT1	5	
6: TxR2		4
7: RxT2		2
8: RxR2		1

## Dialogic® MD1 RJ-45 to MD1 RJ-45 cable

The following illustration shows a Dialogic® MD1 RJ-45 to MD1 RJ-45 cable:

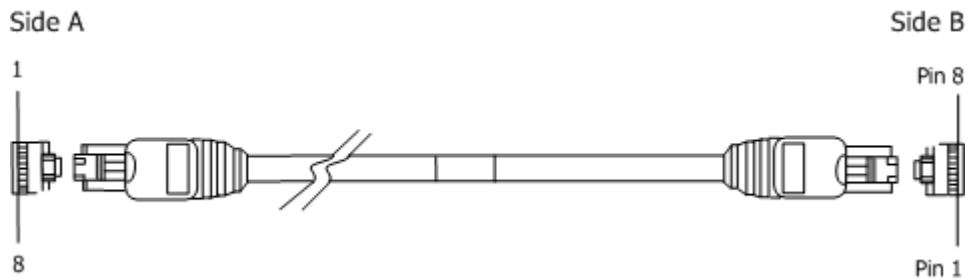

### Pin assignments

The following table provides the pin assignments for RJ-45 to RJ-45 straight cable and the RJ-45 to RJ-45 double crossover cable:

Description	Length	Part number	Side A	Side B	Wiring pairs
Straight cable	36" (91 cm)	83233	1	1	1 and 2
	42" (1.1 m)	83224	2	2	2
	72" (1.8 m)	83235	3	3	3 and 6
			4	4	6
			5	5	4 and 5
			6	6	5
			7	7	7 and 8
			8	8	8
Double crossover cable	36" (91 cm)	83188	1	4	1 and 2
	50" (1.3 m)	83227	2	5	2
			3	7	3 and 6
			4	1	6
			5	2	4 and 5
			6	8	5
			7	3	7 and 8
			8	6	8

## RJ-48C to RJ-48C single crossover cable

The following illustration shows an RJ-48C to RJ-48C single crossover cable:

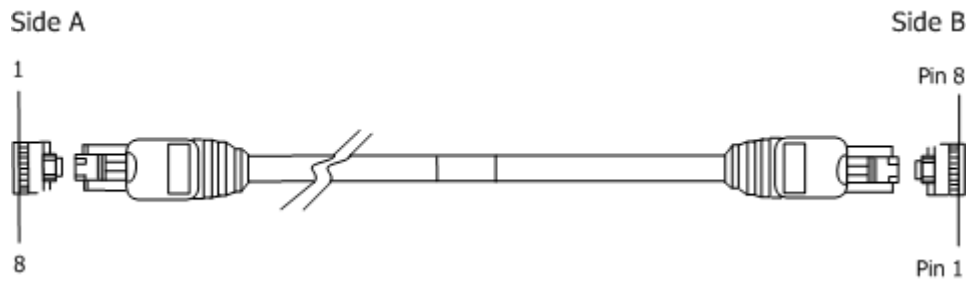

### Pin assignments

The following table provides the pin assignments for an RJ-48C to RJ-48C single crossover cable:

Description	Length	Part number	Side A	Side B
Single crossover cable	36" (91 cm)	83231	1 2 3 4 5 6 7 8	4 5 3 1 2 6 7 8

## Dialogic® MD1 RJ-21 male to MD1 RJ-21 cable

The shielded Dialogic® MD1 RJ-21 male to MD1 RJ-21 cable is available as a straight cable (P/N 83225) or with a right angle (P/N 83228). The following illustrations show these cables:

### P/N 83225:

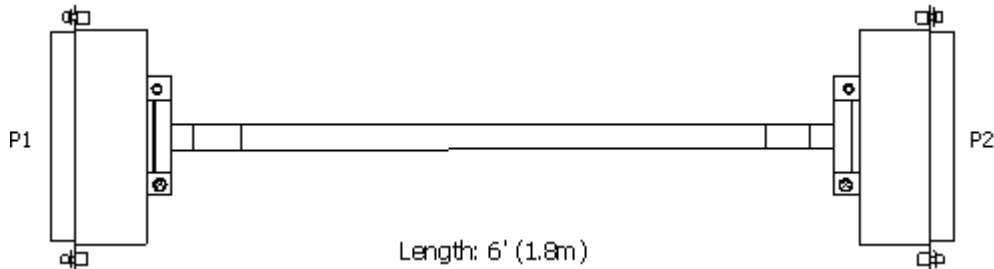

### P/N 83228:

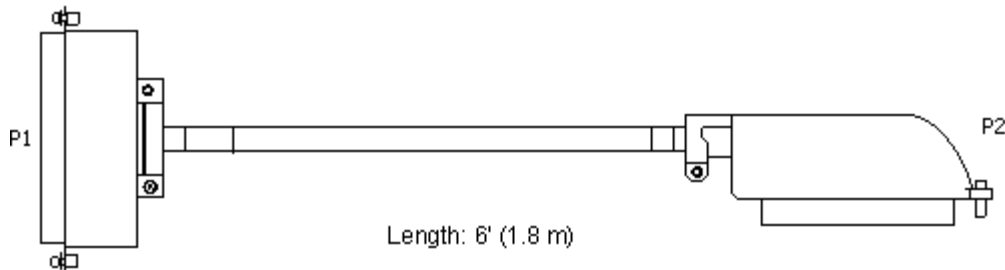

<b>Caution:</b>	The right angle connector does not comply with TIA-568 bend radius specifications (NEBS).
-----------------	---

## Pin assignments

The pin assignments from P1 to P2 are 1:1. Twisted pairs are wired straight through, progressing as follows: 1 and 26, 2 and 27, 3 and 28, 4 and 29, and so forth, up to 25 and 50.

## Dialogic® MD1 Mini RJ-21 to MD1 RJ-21 cable

The following illustration shows the six foot Dialogic® MD1 Mini RJ-21 to MD1 RJ-21 cable (P/N 83226):

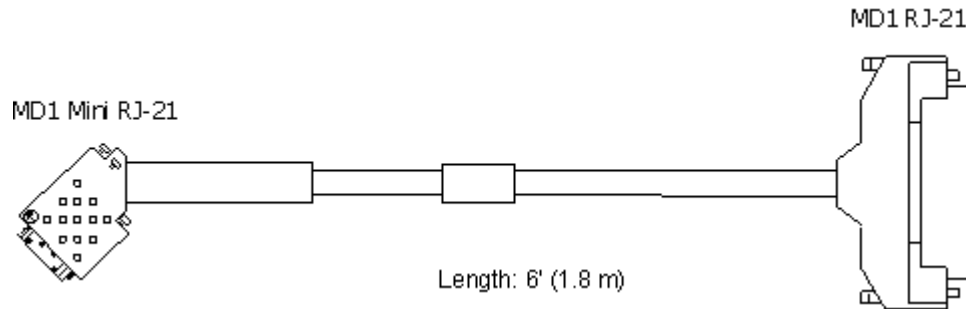

### Pin assignments

The following table lists the Dialogic® MD1 Mini RJ-21 to MD1 RJ-21 cable pin assignments:

Pair	MD1 Mini RJ-21 pin assignments	MD1 RJ-21 pin assignments	Pair	MD1 Mini RJ-21 pin assignments	MD1 RJ-21 assignments
1	1 2	26 1	13	29 30	38 13
2	13 14	27 2	14	41 42	39 14
3	3 4	28 3	15	31 32	40 15
4	15 16	29 4	16	43 44	41 16
5	25 26	30 5	17	9 10	42 17
6	37 38	31 6	18	21 22	43 18
7	27 28	32 7	19	11 12	44 19
8	39 40	33 8	20	23 24	45 20
9	5 6	34 9	21	33 34	46 21

<b>Pair</b>	<b>MD1 Mini RJ-21 pin assignments</b>	<b>MD1 RJ-21 pin assignments</b>	<b>Pair</b>	<b>MD1 Mini RJ-21 pin assignments</b>	<b>MD1 RJ-21 assignments</b>
10	17 18	35 10	22	45 46	47 22
11	7 8	36 11	23	35 36	48 23
12	19 20	37 12	24	47 48	49 24

## RJ-48C to BNC splitter cable

The following illustration shows an RJ-48C to BNC pair splitter cable (P/N 83229):

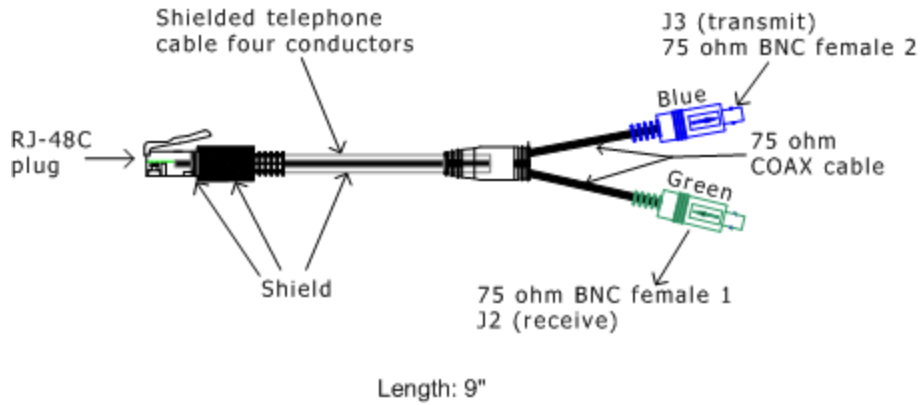

Some countries require different adapter cables. Dialogic offers a BNC splitter cable with the shield connected to transmit and receive outer conductors:

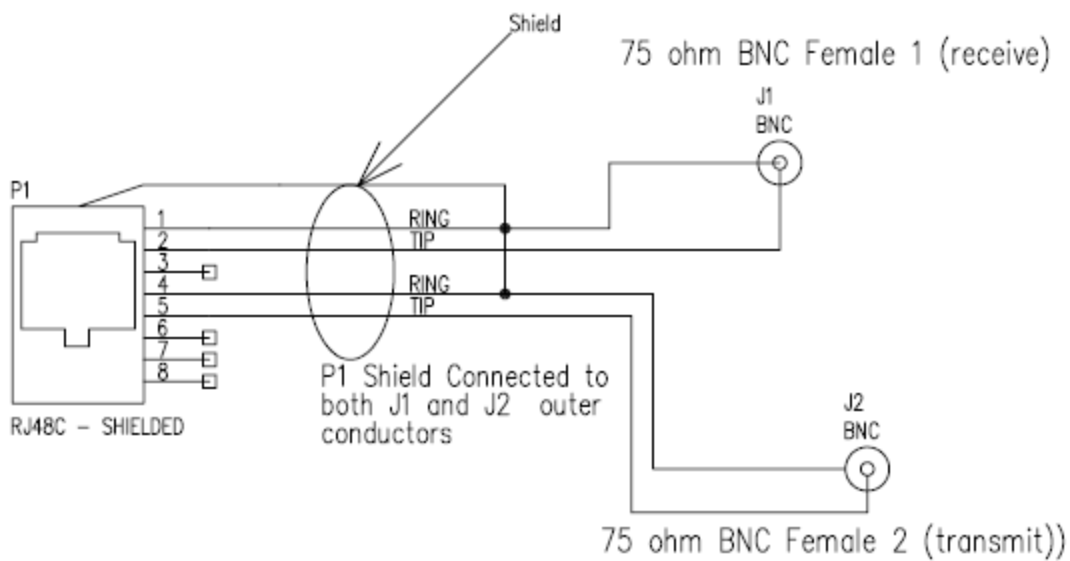

**Note:** This cable does not convert impedance. To connect a CG board with RJ-48C interfaces to a 75-ohm connection, you must either use this cable and configure the board as G703\_75\_OHM, or use an external balun and configure the board for 120-ohm operation.

## Dialogic® MD1 RJ-45 to two BNC pairs splitter cable

The Dialogic® MD1 RJ-45 to two BNC pairs splitter cable (P/N 83232) divides the two trunks on one Dialogic® MD1 RJ-45 to two BNC adapters.

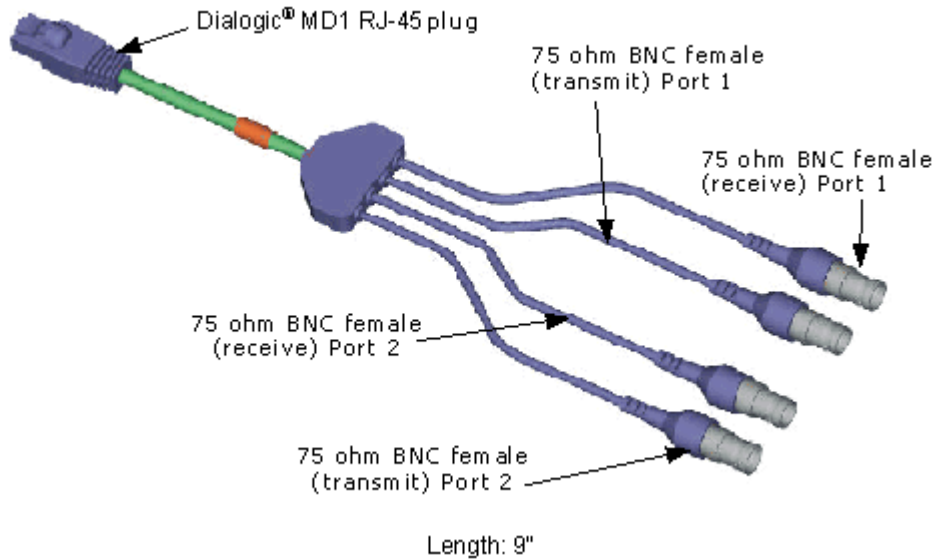

Some countries require different adapter cables. Dialogic offers a splitter cable with the shield connected to transmit and receive outer conductors:

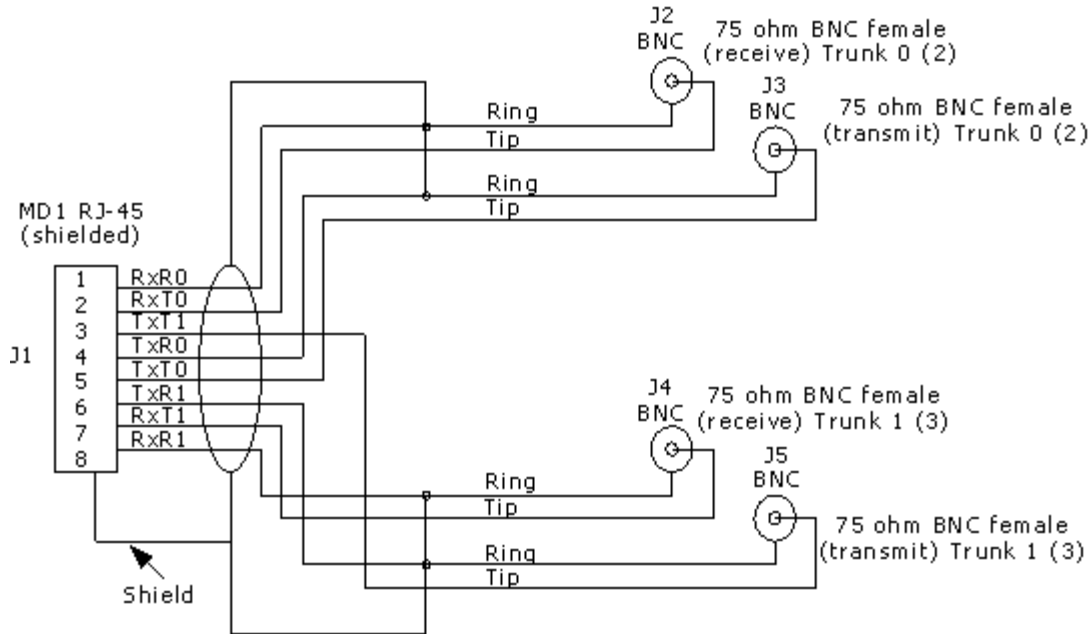

Shield connected to J2, J3, J4, and J5 outer conductors

**Note:** This cable does not convert impedance. To connect a CG board with Dialogic® MD1 RJ-45 interfaces to a 75-ohm connection, you must either use this cable and configure the board as G703\_75\_OHM, or use an external balun and configure the board for 120-ohm operation.

## 5. Dialogic signal entry panel

---

### Overview of Dialogic® signal entry panel

Dialogic® offers a signal entry panel (SEP) to simplify T1/E1 trunk termination. The signal entry panel (P/N 83252) contains two Dialogic® MD1 RJ-21 to RJ-48C breakout modules. Dialogic offers shielded cables to connect Dialogic products with Dialogic® MD1 RJ-21 and Dialogic® MD1 Mini RJ-21 interfaces to the SEP.

#### Rear view

The following illustration shows the two Dialogic® MD1 RJ-21 interfaces on the back of the panel:



#### Front view

The following illustration shows the sixteen RJ-48C interfaces on the front of the panel:

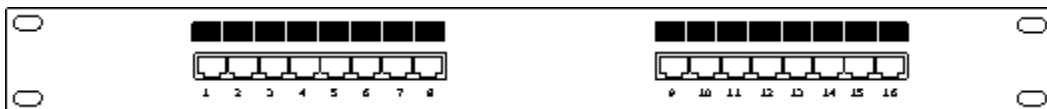

For a list of Dialogic products with Dialogic® MD1 RJ-21 or Dialogic® MD1 Mini RJ-21 interfaces, refer to Interfaces by board type.

If you require other connectivity options or if you prefer to create your own signal entry panel, you can purchase commercially available panels and components from other vendors.

### Dimensions

The following illustration shows the SEP panel dimensions:

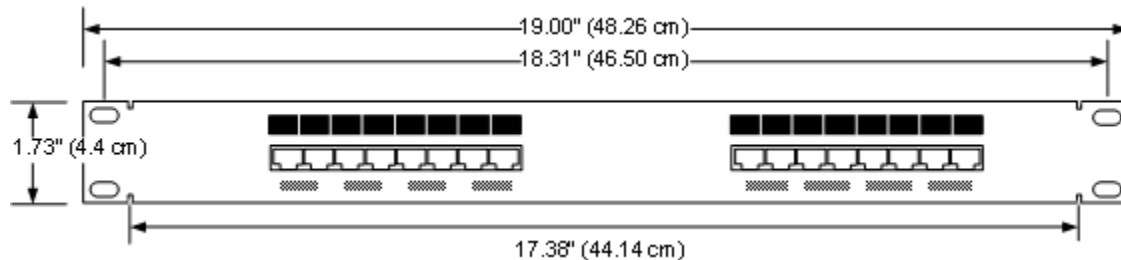

## Schematic

The following illustration shows the signal entry panel schematic:

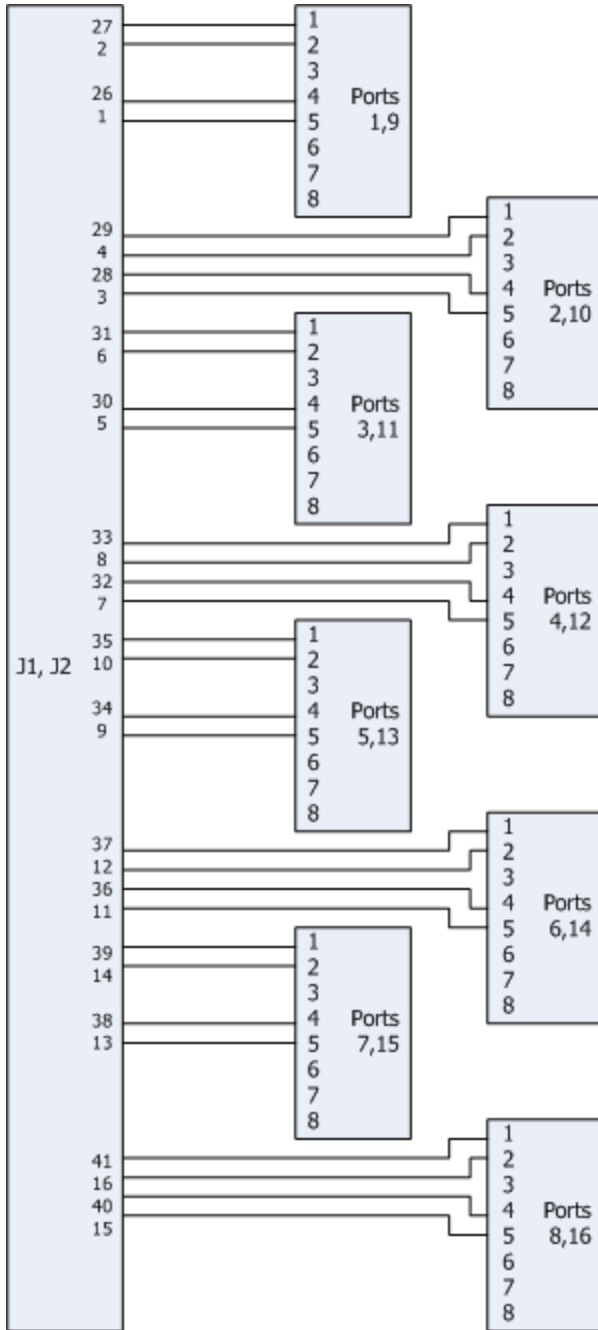

## Cabling the signal entry panel

The cables used to connect to the signal entry panel (SEP) vary based on the interface type on the board you are connecting.

The following illustrations show the cabling used to connect Dialogic® MD1 RJ-21 interfaces and Dialogic® MD1 Mini RJ-21 interfaces to the Dialogic SEP.

### Cabling boards with Dialogic® MD1 RJ-21 interfaces

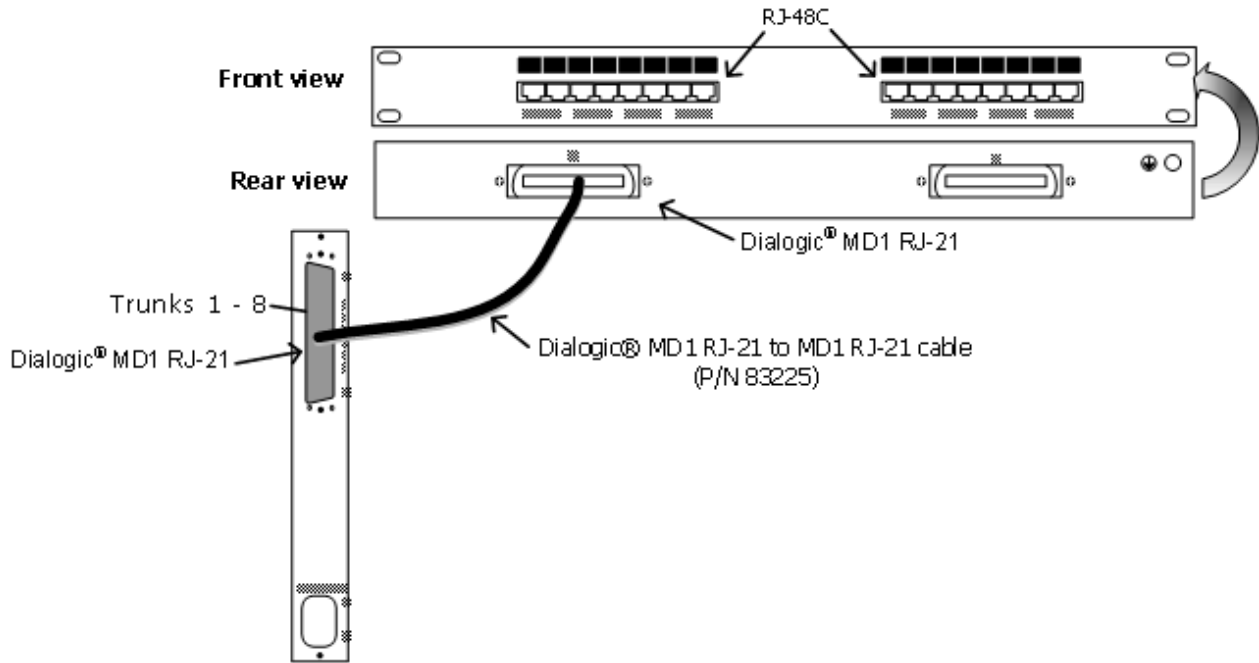

### Cabling boards with Dialogic® MD1 Mini RJ-21 interfaces

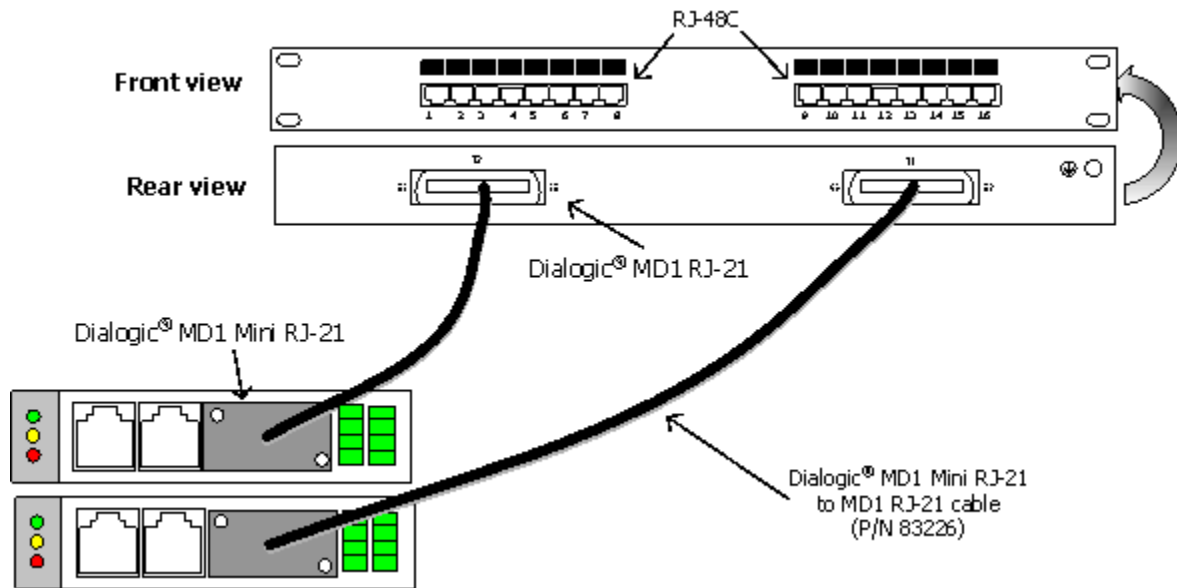

## Signal entry panel kits

Dialogic offers the following kits containing signal entry panels and cables:

Description	Part number	Contents
SEP/cable kit – 1X (MD1 RJ-21 to (8) RJ-48C interface), 1U	82923-1	One SEP (P/N 83252) and one MD1 RJ-21 to MD1 RJ-21 cable (P/N 83225)
SEP/cable kit – 2X (MD1 RJ-21 to (8) RJ-48C interface), 1U	82923-2	One SEP (P/N 83252) and two MD1 RJ-21 to MD1 RJ-21 cables (2 x P/N 83225)
SEP/cable kit – 1X (MD1 MRJ-21 to (8) RJ-48C interface), 1U	82924-1	One SEP (P/N 83252) and one MD1 Mini RJ-21 to MD1 RJ-21 cable (P/N 83226)
SEP/cable kit – 2X (MD1 MRJ-21 to (8) RJ-48C interface), 1U	82924-2	One SEP (P/N 83252) and two MD1 Mini RJ-21 to MD1 RJ-21 cables (2 x P/N 83226)

## 6. Miscellaneous components and certifications

---

### RJ-48C to 75 ohm BNC connector pair transformer

The following illustration shows a single balun transformer with one RJ-48C to dual 75 ohm BNC connector pair for converting from 120 to 75 ohms (P/N 83236).

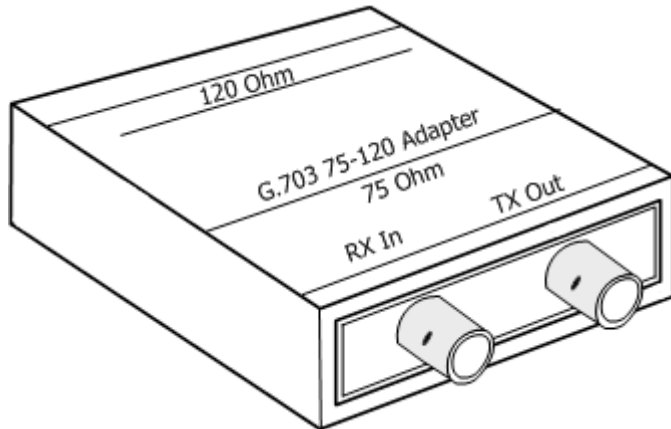

## Punchdown block

Dialogic offers a punchdown block (P/N 83237) to simplify T1/E1 trunk termination. The punchdown block contains two Dialogic® MD1 RJ-21 to RJ-48C breakout modules. Dialogic offers shielded cables to connect Dialogic® products with Dialogic® MD1 RJ-21 interfaces to the punchdown block.

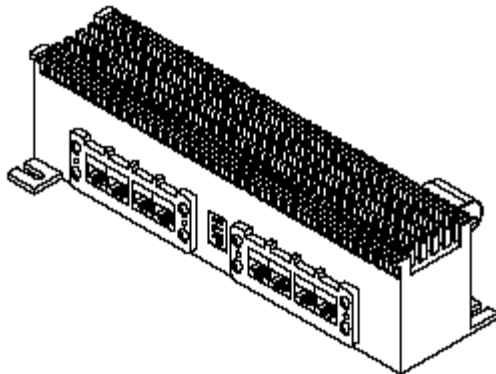
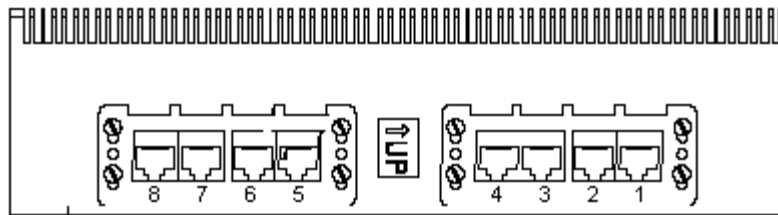
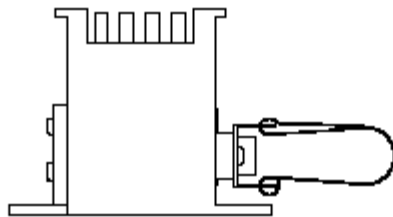
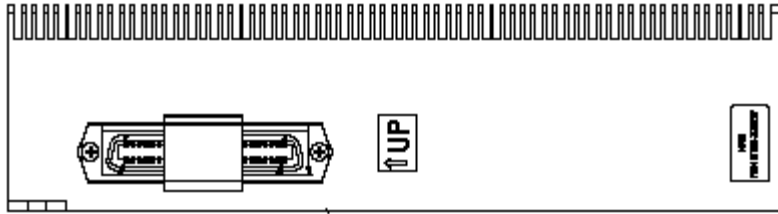

## Schematic

The following illustration shows the punchdown block schematic:

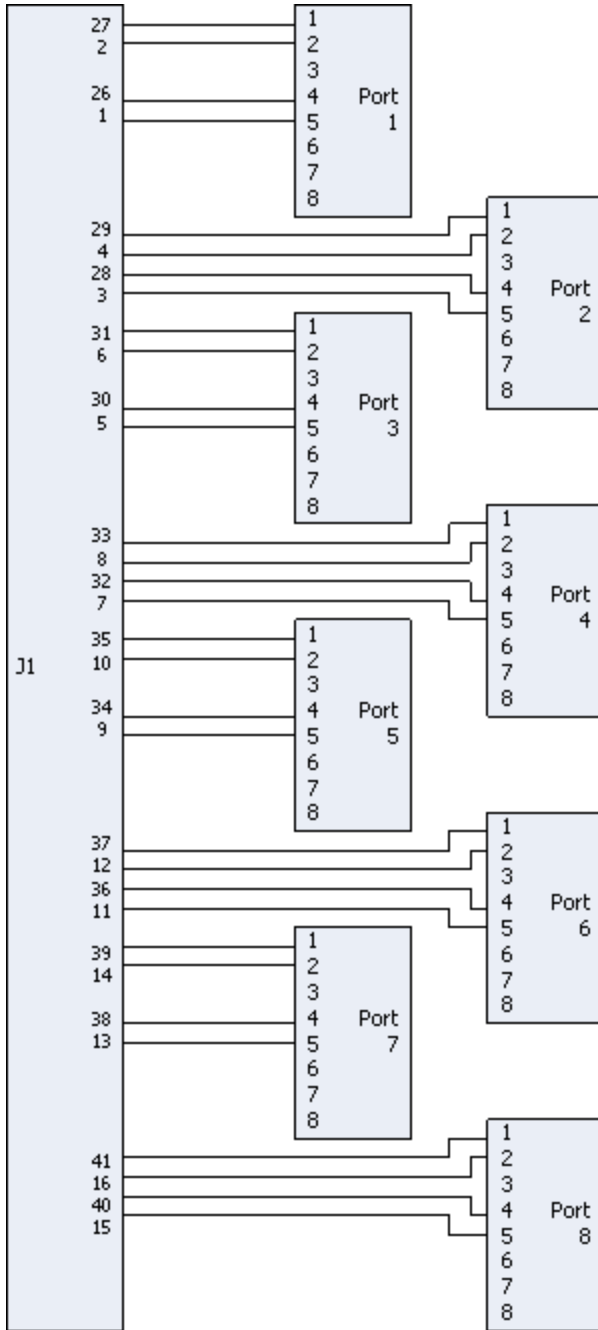

## Compliance and regulatory certification

Dialogic obtains board-level approval certificates for supported countries. In addition to the approval obtained by Dialogic for the board and its associated software, some countries require a system-level approval before connecting the system to the public network. To learn what approvals you require, contact the appropriate regulatory authority in the target country.

### Safety

Country	Standard
US	UL Std No 60950-1
Canada	CAN/CSA-C22.2 No 60950-1-03
EU	EN 60950-1:2001

# Index

---

<b>C</b>	
cables.....	12
cabling.....	23
certifications.....	28
compliance.....	28
components.....	21
crossover cables .....	15
<b>D</b>	
Dialogic® MD1 Mini RJ-21 interface.....	9
Dialogic® MD1 RJ-45 interface .....	7
Dual T1/E1 120 ohm adapter cable.....	13
<b>E</b>	
Ethernet connectors .....	6
<b>G</b>	
glossary.....	5
<b>I</b>	
interfaces.....	7, 8, 9, 10
<b>M</b>	
MD1 Mini RJ-21 interface.....	9
MD1 Mini RJ-21 to MD1 RJ-21 cable.....	17
MD1 RJ-21 interface .....	8
MD1 RJ-45 interface .....	7
MD1 RJ-45 to two 75 ohm BNC splitter cable .....	20
<b>P</b>	
punchdown block .....	26
<b>R</b>	
RJ-21 to RJ-21 cable.....	16
RJ-45 Ethernet connectors .....	6
RJ-45 to RJ-45 cables .....	14
RJ-48C interface .....	6
RJ-48C to 75 ohm BNC connector pair transformer .....	25
RJ-48C to BNC splitter cable.....	19
RJ-48C to RJ-48C single crossover cable	15
<b>S</b>	
schematic.....	19, 20, 22
splitter cables .....	19, 20
<b>T</b>	
terminology.....	2