



Building Fault-Tolerant SS7 Systems Using the Dialogic® SS7G2x Signaling Servers with the SIU Option

Executive Summary

In order to achieve five-nines (99.999%) reliability and a high degree of fault tolerance in an SS7 environment using Dialogic® SS7G2x Signaling Server with the SIU option, an SS7 end point spread over two signaling interface units (SIUs) and multiple application servers can be configured and deployed. Splitting the protocol processing functionality of a signaling point by implementing an SS7 node over two SIUs isolates the hardware processors on the chassis from each other. This separation lets one unit continue if the other fails, allowing the system to remain in service. Distributing application processing of a signaling point on multiple application servers not only increases the total capacity of a system, but also offers a higher level of fault tolerance in the user application space.

Dialogic® SS7 products are designed for this dual-unit approach and provide the architecture for splitting one or multiple local point code(s) over two active SS7 protocol engines. Using this technique, the links in an SS7 link set can be spread between two separate chassis when Dialogic SS7 boards are installed in each.

This document describes the features of the SS7G2x SIU that are available to build SS7 solutions and reach the five-nines requirements of telco-grade service platforms.

Table of Contents

Introduction.....	2
Overview of SIU Operation.....	2
Circuit-Switched API Operation.....	3
Transaction-Based API Operation.....	4
Management Interface.....	4
Potential Points of Failure.....	4
Failure of SS7 Links.....	5
Failure of Routes.....	5
Failure of Power Supply.....	7
Failure of Hard Disk Drive.....	7
Failure of Signaling Interface Unit.....	7
Failure of IP Connection.....	15
Failure of IP Subnetwork.....	16
Failure of Application.....	16
Configuring a Dual SIU Pair.....	17
Hardware Requirements.....	18
System Configuration.....	18
Run-Time Operations of a Dual-Resilient SIU System.....	22
Connecting a Host to Two SIUs.....	22
Communicating with Both SIUA and SIUB.....	22
Transferring Control of a Circuit Group between SIUs.....	22
Appendix A: Frequently Asked Questions.....	26
Acronyms.....	26
For More Information.....	26

Introduction

This application note describes the architecture of the Dialogic® SS7G2x Signaling Server with the SIU option, reviews the most common potential points of failure of an SS7 system based on this product, and explains methods that can be used to mitigate each of these potential failure points. This document also explains in detail the configuration and run-time operation considerations of a dual-resilient SIU-based system.

Because of the high expectation of service reliability by the users of public telephone networks, equipment manufacturers and system integrators demand high levels of fault tolerance and availability, often citing the five-nines standard for availability (requiring a system to be operational for 99.999% of the time).

These systems need to continue to offer service even when partial hardware or software failure has occurred. There are several well-known methods of achieving this type of reaction to partial failure in the signaling component of communications networks, including:

- Multiple signaling paths (SS7 links and link sets) to each end point
- Distribution of these paths through independent interfaces and cabling
- Distribution of the processing of SS7 terminations at a single signaling point between multiple processing cards in a single SIU
- Physical isolation and duplication of the SS7 interface for a single signaling point on independent protocol engines sharing a single point code
- Splitting the functionality of the application layer between multiple application servers

The first method can be achieved by implementing multiple links (either 64 Kb/s or 56 Kb/s low-speed link channels or 2 Mb/s high-speed link channels) between two adjacent inter-communicating points. (By definition, these links will all be in the same link set.) The last two can be accomplished by using two independent, but co-operating, SIUs relaying the SS7 signaling to a distributed application layer split over multiple application hosts.

Note: Readers should be familiar with Signaling System 7 (SS7) concepts. They should also be aware that the information contained in this application note is provided as a complement to the *Dialogic® SS7G2x Signaling Server: SIU Mode User Manual*; hence, an understanding of the terms defined in the user's manual is assumed.

Overview of SIU Operation

The Dialogic SS7G2x Signaling Server with the SIU option is an SS7 network access product that provides a resilient interface to SS7 networks via a TCP/IP local area network (LAN). SIU software includes SS7 and SIGTRAN protocol layers, as well as a configuration and management module (see Figure 1). The SIU supports multiple SS7 signaling links within the same pulse code modulation (PCM) trunk interface or over multiple PCM trunks. The SIU examines the time slots carrying the SS7 information and processes them accordingly, outputting this data to the LAN using TCP/IP. Similarly, it takes commands from the TCP/IP LAN and converts those to SS7 signals for transmission to the SS7 network. In the receive direction, information is conveyed to the user application in structured messages placed in a sequential queue.

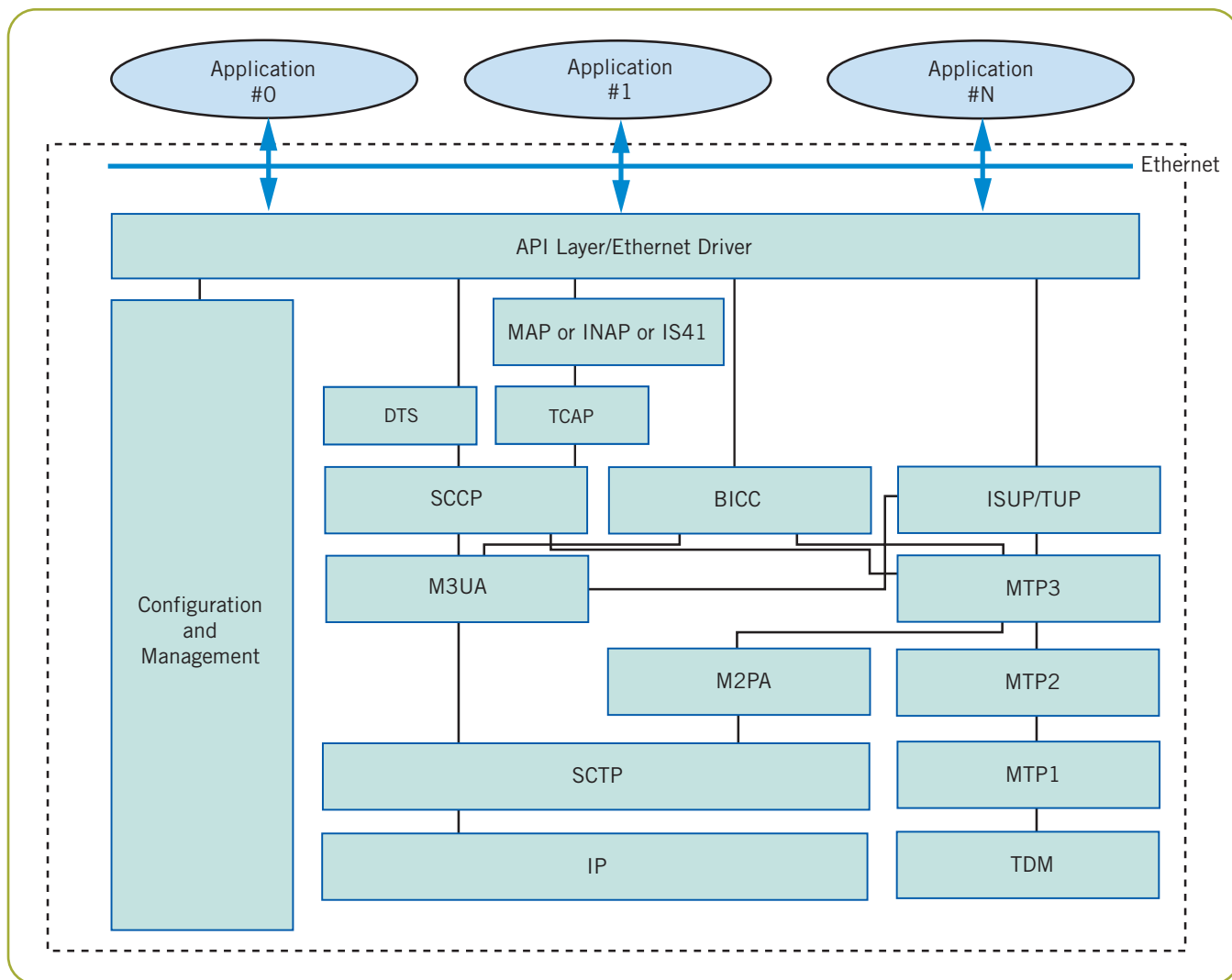

Figure 1. Structure of the Dialogic® SS7G2x SIU

The SS7G2x signaling servers are available in two different versions:

- The SS7G21, which is based on Dialogic® low-density signaling cards (SPCI4 or SPCI2S), can process up to 12 SS7 low-speed links (that is, 64 Kb/s each)
- The SS7G22, which is based on Dialogic® high-density signaling cards (SS7HDP4TE), can process up to 128 SS7 low-speed links or 6 SS7 high-speed links (that is, 2 Mb/s each)

For both circuit- and transaction-related operations, the SIU provides the ability to automatically distribute signaling information between a number of physically independent application platforms, thus providing a degree of fault tolerance within the application space.

The SS7 signaling may be presented from the network multiplexed in a time slot on an E-1 (2.048 MB/s) or T-1 (1.544 MB/s, also known as DS1) bearer, by a V.35 (56/64 Kb/s) synchronous serial interface, or over SIGTRAN M2PA or M3UA on one of the SIU Ethernet ports.

For telephony operation (using a telephony layer 4 protocol such as ISUP, TUP, or BICC), if the SS7 signaling is multiplexed onto a PCM bearer, the voice circuits may be passed transparently through the SIU to the application platform that terminates the physical circuits (see Figure 2).

Circuit-Switched API Operation

The message-based application programming interface (API) operates transparently over TCP/IP Ethernet, using Dialogic® software modules. For circuit-switched

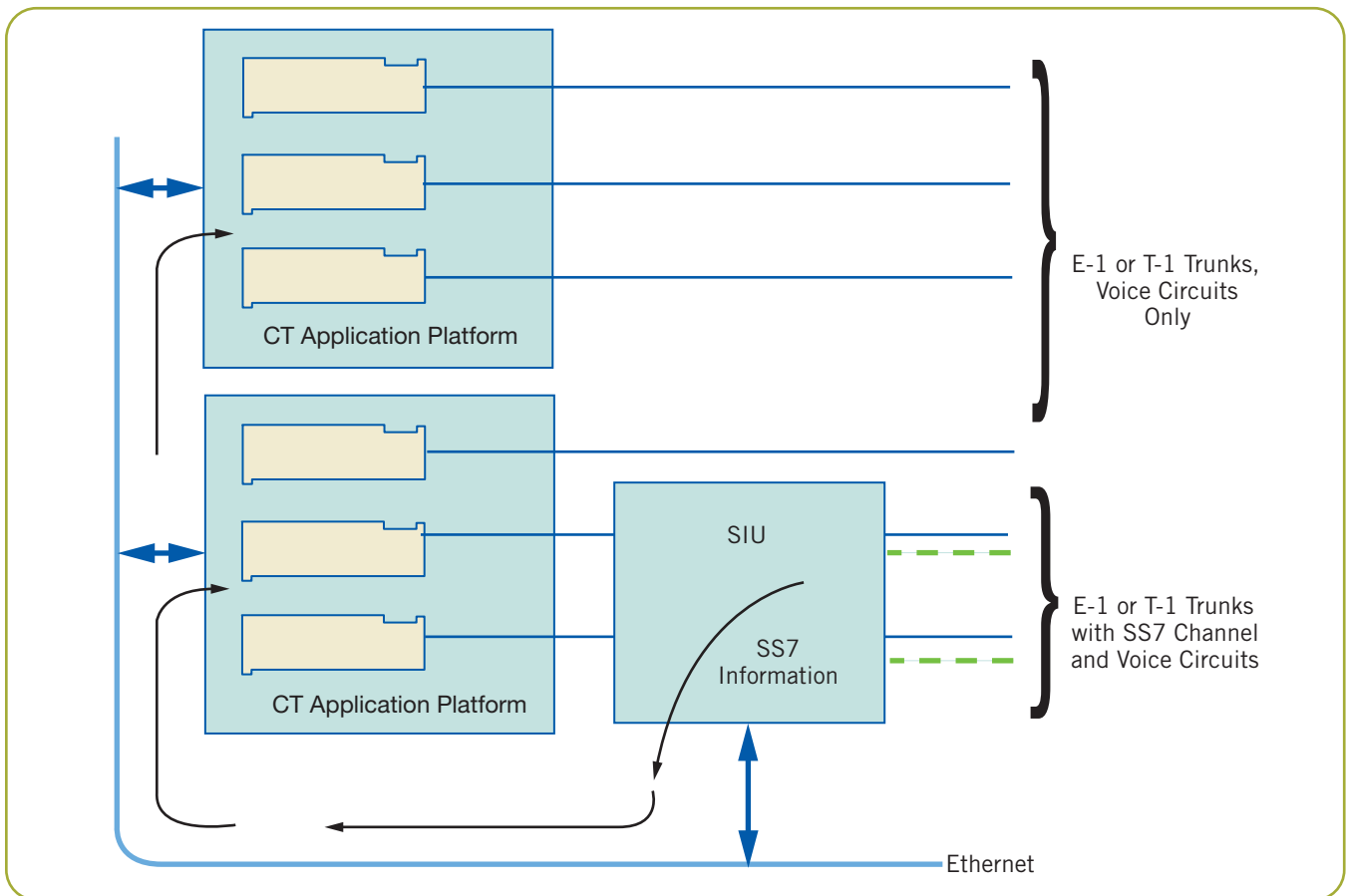

Figure 2. Integrating the SIU

(telephony) applications, each application platform terminates and thus controls a fixed range of physical circuits, or circuit identification codes (CICs). CICs are configured in groups of up to 32, each group normally equating to all the circuits in a single E-1 or T-1 trunk. Each group is terminated on a fixed application platform or host processor, enabling the SIU to automatically direct API messages to the correct platform.

Transaction-Based API Operation

TCAP-based applications can be distributed on multiple application hosts using two different methods, which are explained in detail in this document (see “Failure of Application” below). These methods imply running TC-user application parts (such as GSM-MAP, INAP, or IS-41) on each application host. When running any application part above TCAP on the SIU itself, the product allows operation of a single host application.

Management Interface

The SIU constantly monitors the state of its physical connections, PCM trunk inputs, the communication

channel using TCP/IP Ethernet to the host processors, and reports status information to an application process running on a user-defined host. The host elected to receive management messages can be selected by sending an **API_MSG_COMMAND** management request. (See the *Dialogic® SS7G2x Signaling Server: SIU Mode User Manual* for more information.) Host 0 is used by default.

Potential Points of Failure

In this section, the most critical points of failure of a Dialogic® SIU-based system are reviewed. The list of potential points of failure include:

- SS7 links
- SS7 routes
- Power supply
- Hard disk drive
- Signaling interface unit
- IP connections
- IP subnetwork
- Application host

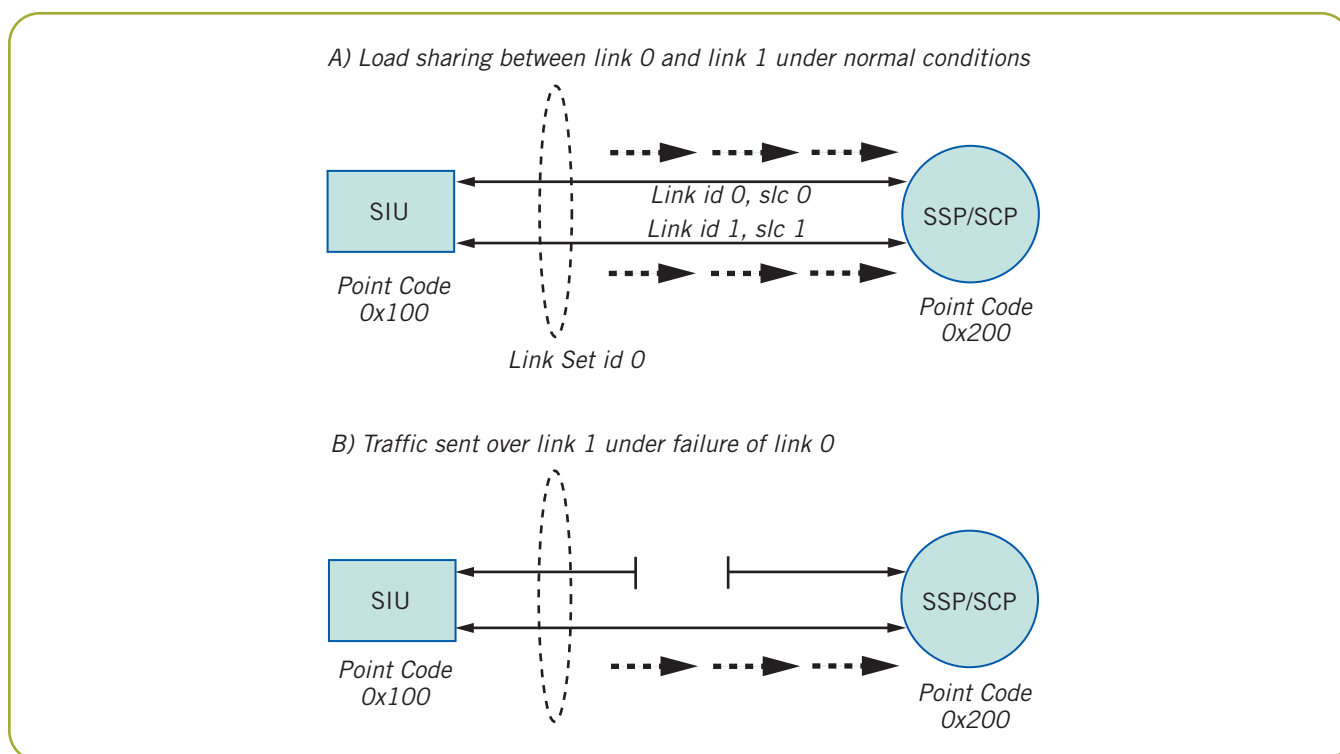

Figure 3. SIU Connected to Adjacent Node with Two Links in Link Set

For each of these points of failure, a solution is provided and implementation details are given.

Failure of SS7 Links

Problem — With a single link to the adjacent signaling point, service is disrupted if the link goes down for some reason (for example, layer 1 alarm, congestion).

Solution — Link resiliency is achieved by using multiple links between a local point code and an adjacent point code. Such links are said to belong to the same link set, which can contain up to 16 links. Ideally, the links of a link set should not be carried over a unique physical medium (such as an E-1 or T-1 trunk) but, instead, should be split over independent physical trunks. Link failure management is a standard MTP3 operation and is not an SIU-specific feature. In other words, failure between links in a same link set will happen in a completely transparent way for the user application.

Details — In an SIU system configuration, two commands are used in config.txt to configure link sets and links: **MTP_LINKSET** and **MTP_LINK**. In this example, two SS7 links are defined between local point code 0x100 and adjacent point code 0x200 on time slot 16 of PCM ports 1 and 2 (see Figure 3).

```
* MTP_LINKSET <linkset_id> <adjacent_spc> <num_links> <flags> <local_spc> <ssf>
MTP_LINKSET 0 0x200 2 0x0000 0x100 0x08

* MTP_LINK <link_id> <linkset_id> <link_ref> <slc> <bpos> <blink> <bpos2>
*<stream> <timeslot> <flags>
MTP_LINK 0 0 0 0 0 0 0 0 16 0x0006
MTP_LINK 1 0 1 1 0 1 0 1 16 0x0006
```

Failure of Routes

Problem — With a single route to a destination point code (DPC), service can be disrupted if all the links of the link set used to reach that signaling node fail.

A) Load sharing between link set 0 and link set 1 under normal

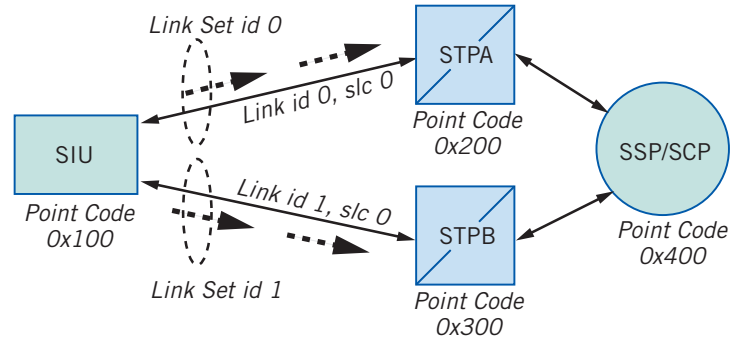

B) Traffic sent over link set 1 under failure of STP

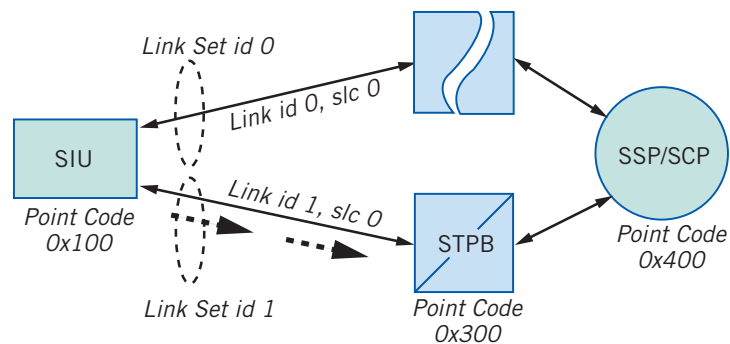

Figure 4. SIU Connected to Mated STP Pair Providing Route Resiliency

Solution — To eliminate this single point of failure, an alternative link set can be provided in the SIU system configuration to reach the same DPC. Route failover is a standard MTP3 operation that does not require any specific action from the user application.

Note: When an alternative route to a given DPC is defined in an SIU configuration file, a choice must be made between two different traffic modes: load sharing or failover. In load-sharing mode, traffic sent towards the remote signaling point is shared between the two link

sets. In failover mode, all traffic sent towards the remote signaling point will normally be sent using the primary link set, unless this link set fails, in which case the traffic will use the alternative link set. See the *Dialogic® SS7G2x Signaling Server: SIU Mode User Manual* for more information on the selection of traffic mode in the `MTP_ROUTE` command.

Details — This example (see Figure 4) shows two link sets (each containing one link) being used in load-sharing mode to reach destination point code 0x400.

```
* MTP_LINKSET <linkset_id> <adjacent_spc> <num_links> <flags> <local_spc> <ssf>
MTP_LINKSET 0 0x200 2 0x0000 0x100 0x08
MTP_LINKSET 1 0x300 2 0x0000 0x100 0x08

* MTP_LINK <link_id> <linkset_id> <link_ref> <slc> <bpos> <blink> <bpos2>
* <stream> <timeslot> <flags>
MTP_LINK 0 0 0 0 0 0 0 0 16 0x0006
MTP_LINK 1 0 1 1 0 1 0 1 16 0x0006
MTP_LINK 2 1 0 0 0 2 0 2 16 0x0006
MTP_LINK 3 1 1 1 0 3 0 3 16 0x0006

* MTP_ROUTE <dpc> <linkset_id> <user_part_mask> <flags> <second_ls> <pc_mask>
MTP_ROUTE 0x400 0 0x0020 0x0003 1 0x00000000
```

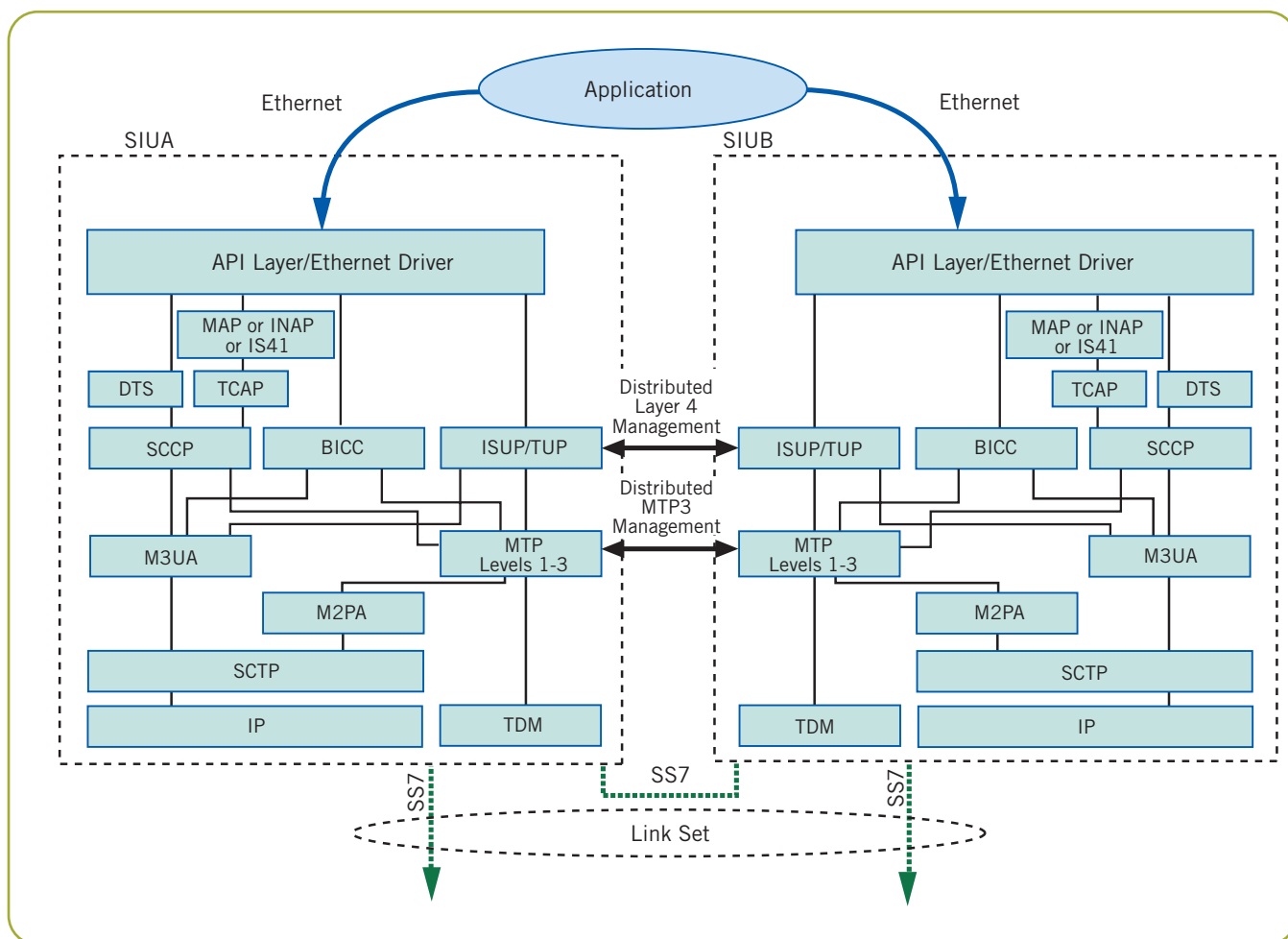

Figure 5. Dual SIU Architecture

Failure of Power Supply

Problem — Ensuring that the unit survives the loss of one power supply and making it possible to replace a failed power supply without affecting the availability of the system.

Solution — The Dialogic SS7G2x Signaling Server can be optionally configured with a redundant and hot swappable power supply.

Details — Refer to *Dialogic® SS7G21 and SS7G22 Signaling Servers: Hardware Manual* to obtain part numbers for redundant power supplies for the SS7G2x Signaling Server.

Failure of Hard Disk Drive

Problem — The failure of the SIU hard disk drive (HDD) means that the SIU is out of service and has to be shipped back to Dialogic for repair.

Solution — A spare SIU HDD (pre-loaded with the proper Operating System and SIU software) can be

purchased from your Dialogic reseller and can be manually replaced on a failed unit in the field.

Details — The SIU unit has to be upgraded to software version V4.05 or later in order to benefit from the spare HDD functionality. Refer to the V4.05 release notes for additional information on how to back up and restore your protocol licenses and configuration files when replacing the SIU HDD.

Failure of Signaling Interface Unit

Problem — Since the SIU provides an SS7 interface to a distributed application, it is usually deployed for high-density service platforms. Should the SIU of a single SIU-based system fail, many resources (telephony circuits and/or TCAP dialogues) would become unavailable and would cause major service disruption.

Solution — A major feature of the SIU architecture is that two units can be configured to operate as a single entity, sharing up to four local SS7 point codes. In

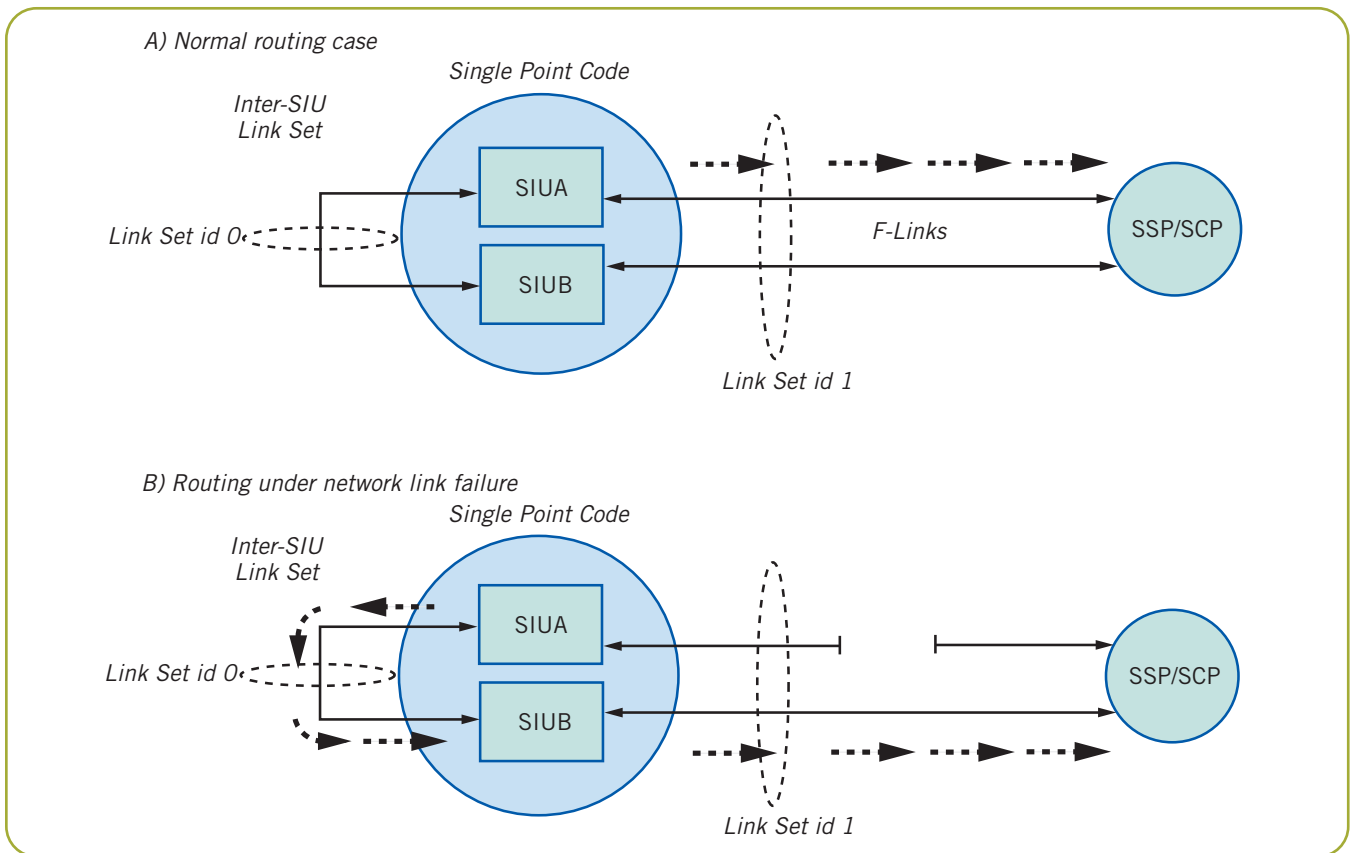

Figure 6. Transmit Routing to a Single Destination

normal operation, signaling can be shared between two units. In the event of a failure, signaling is maintained by the remaining unit.

Details — In a dual configuration, one unit is assigned as SIUA, the other as SIUB. Under normal operation, the application uses the resources of both SIUA and SIUB (see Figure 5).

The distributed layer 4 management is achieved using a LAN connection and allows SS7 messages for any transaction or call to be received by either unit, regardless of which unit is actually processing the call or transaction.

The distributed MTP3 functionality is achieved using a specially configured inter-SIU link set, containing one or more signaling links. As of SS7G2x SIU software V4.00, this inter-SIU link set can be enabled using SIGTRAN M2PA protocol. Transmit messages from each SIU are load shared between links that connect to the local SIU, if these are available. If all local network-facing SS7 links have failed, transmit messages are relayed to the partner SIU across the inter-SIU link set and sent out to the adjacent signaling point by the partner unit. The inter-

SIU link set also provides the capability of message retrieval and retransmission when a changeover operation occurs between the two units.

- For circuit-switched applications, the circuit groups are configured on both units, letting the application select which SIU controls each group. In normal operation, the control of circuit groups is distributed between both the SIUA and SIUB. In the event of failure of a unit (or for maintenance), the application can move control of each circuit group from one SIU to the other.
- For transaction-based applications, the transactions are shared equally between the two units.

Routing Architectures of a Dual-Resilient SIU System

The routing options (that is, straight connection to the DPC versus indirect connection via a pair of STPs) described in this section will vary based on the actual network architecture that is being supported for a particular application.

Connection to a Single Adjacent Signaling Point

Figure 6 shows the two possible routing alternatives for SIUA routing to an adjacent SSP or SCP. Messages issued

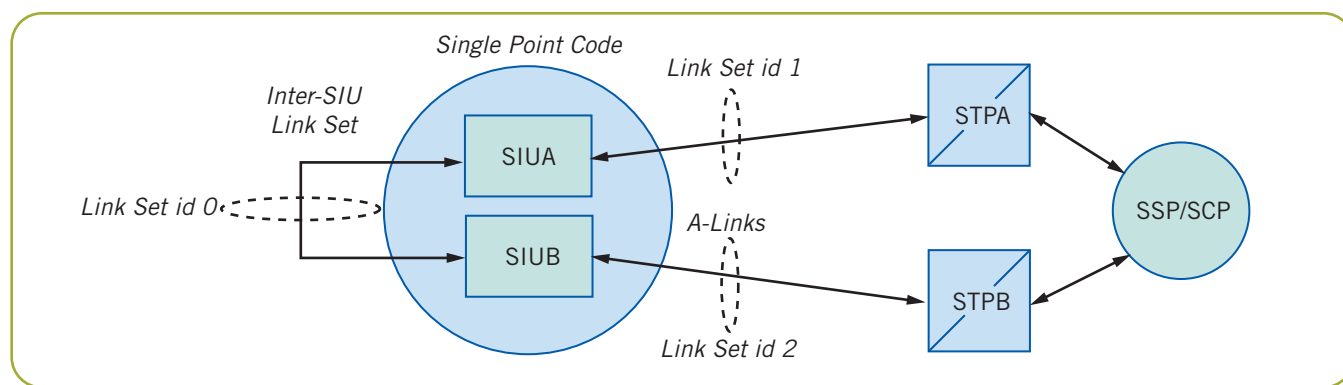

Figure 7. Dual-Resilient SIUs Connected to a Mated STP Pair in a Straight Link Configuration

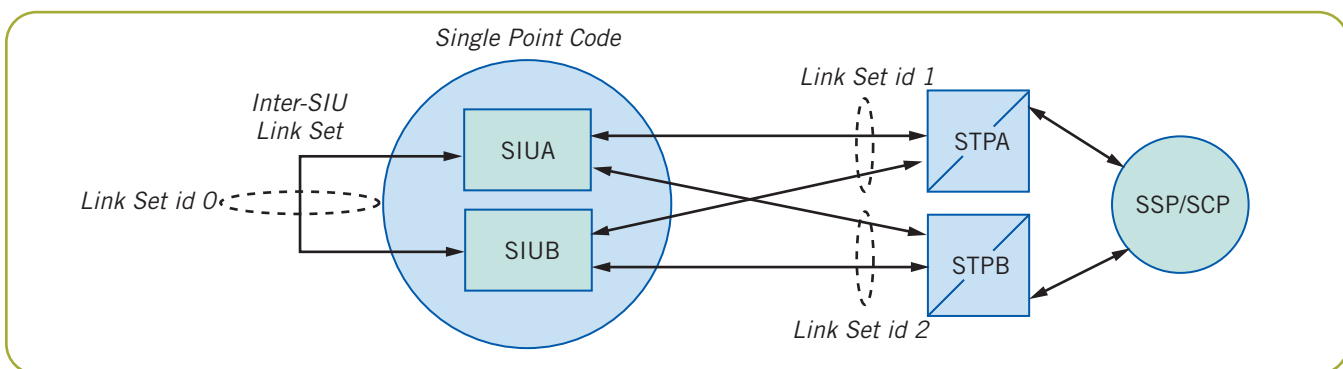

Figure 8. Dual-Resilient SIUs Connected to a Mated STP Pair in a Crossed Link Configuration

from SIUA are sent to the destination SSP or SCP using local SS7 links, if available. If these fail, transmit messages are relayed through SIUB over the inter-SIU links. In this case, the DPC is also the adjacent signaling point. Although Figure 6 shows an SIU pair connected to a single adjacent signaling point, the pair may be connected to multiple destinations.

When using SIGTRAN M2PA protocol to enable the inter-SIU link set, a single M2PA link is enough as it provides enough bandwidth to cope with the traffic it might have to transport. Using M2PA helps preserve the total link resources and PCM interfaces so they can be used exclusively by network facing connections.

When using traditional TDM-based MTP2 protocol to enable the inter-SIU link set, the number of links allocated in that link set is carefully calculated. Since these links will be used for outgoing traffic only, they can be used at a higher capacity than network-facing links. Moreover, since only half of the traffic can potentially be routed through that link set, a common rule is to allocate one-fourth of the total number of network-facing links in the inter-SIU link set.

Routes to destinations are configured such that there is a

primary link set (the link set from the SIU to the DPC) and a secondary link set (the inter-SIU link set) which is used only when the primary link set has failed.

In case (A), since the F-links all exist in the same link set, messages may be sent from the adjacent SSP/SCP to either SIUA or SIUB. If an SIU receives a message from the SS7 network for a circuit or transaction that it does not control, this receive message is passed automatically to the other SIU for processing via the TCP/IP LAN.

Connection to an Adjacent Mated STP Pair

There are two ways of connecting a pair of SIUs to a mated STP pair. In the first method, the straight link configuration, each SIU is configured with two link sets: one link set containing STP-facing links, plus the inter-SIU link set. The straight link configuration consists of connecting SIUA to STPA and SIUB to STPB (see Figure 7).

The second method, the crossed link configuration, consists of adding crossed link connections (between SIUA and STPB and between SIUB and STPA) to the previous mode. In a crossed link configuration, each SIU is configured with three link sets: two link sets containing the links towards each STP, plus the inter-SIU link set (see Figure 8). The configuration of the DPC will contain

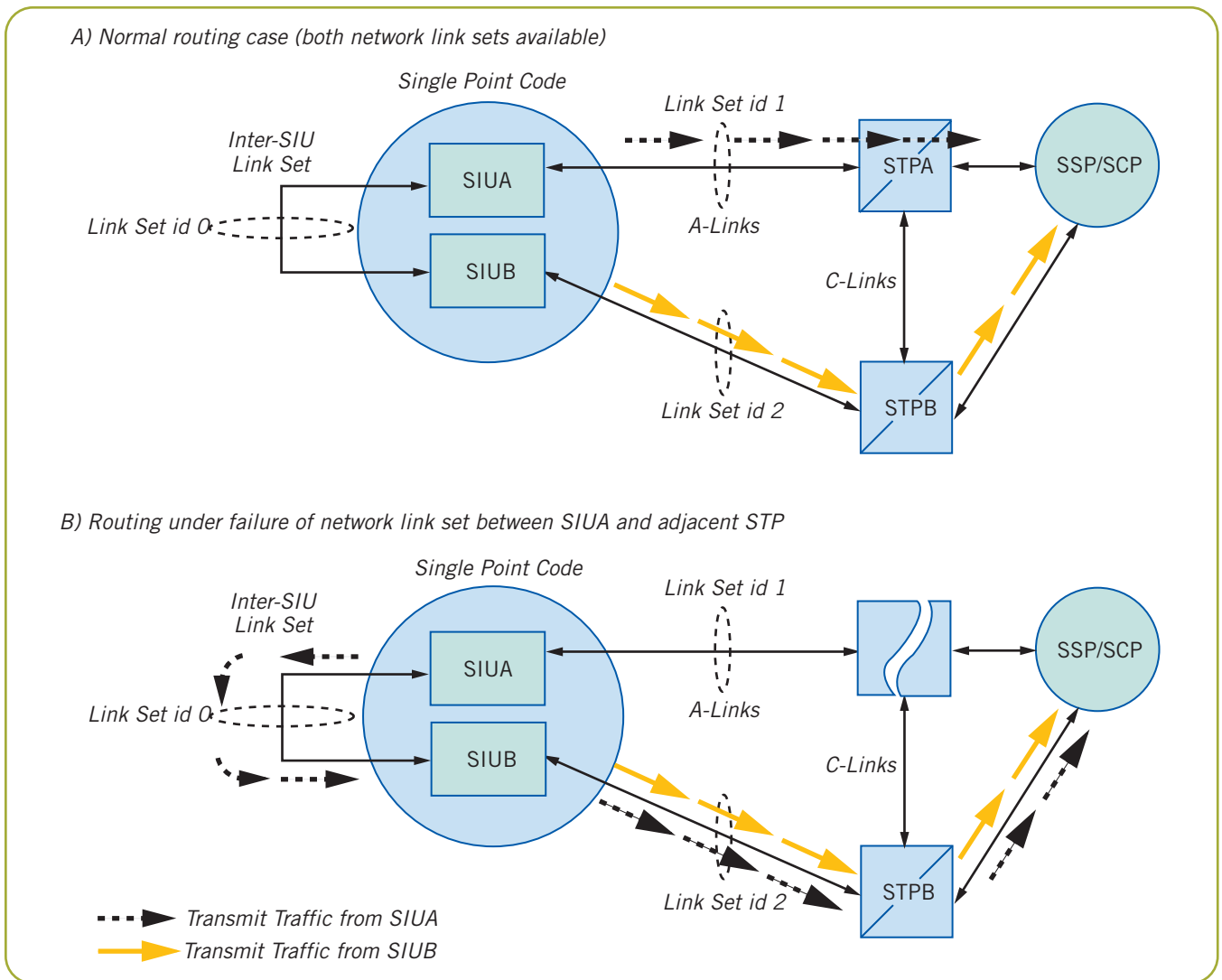

Figure 9. Transmit Routing Through Mated STPs

the link set IDs of the two link sets connected to the STPs. Load sharing can be enabled to take advantage of all the system resources. In such a configuration, the inter-SIU link set is not used for traffic failover, but only for synchronization of network management messages. Consequently, a single link within this link set is enough, giving an increased bandwidth for network-facing links.

The inter-SIU link must be carefully dimensioned as it will have to support the outgoing traffic of the SIU that would have lost its entire network-facing links (see Figure 9). Again, a common practice is to allocate one-fourth of the total number of network-facing links in the inter-SIU link set. Note, however, that this is not a constraint when using SIGTRAN M2PA for enabling the inter-SIU link set.

Table 1 compares these methods.

Comparison Subject	Straight Configuration	Crossed Configuration
Load sharing	STPA can only load share traffic for SIUA and vice versa	Each STP can load share between two SIUs, optimizing the resource utilization
Network-facing links failure	SIUA can rely on SIUB to send outgoing traffic upon failure of its entire network-facing links	When an SIU loses its network-facing links, the application must activate circuit groups on the surviving SIU (for ISUP-based application)

Table 1. Comparison of a Straight Link Configuration versus a Crossed Link Configuration

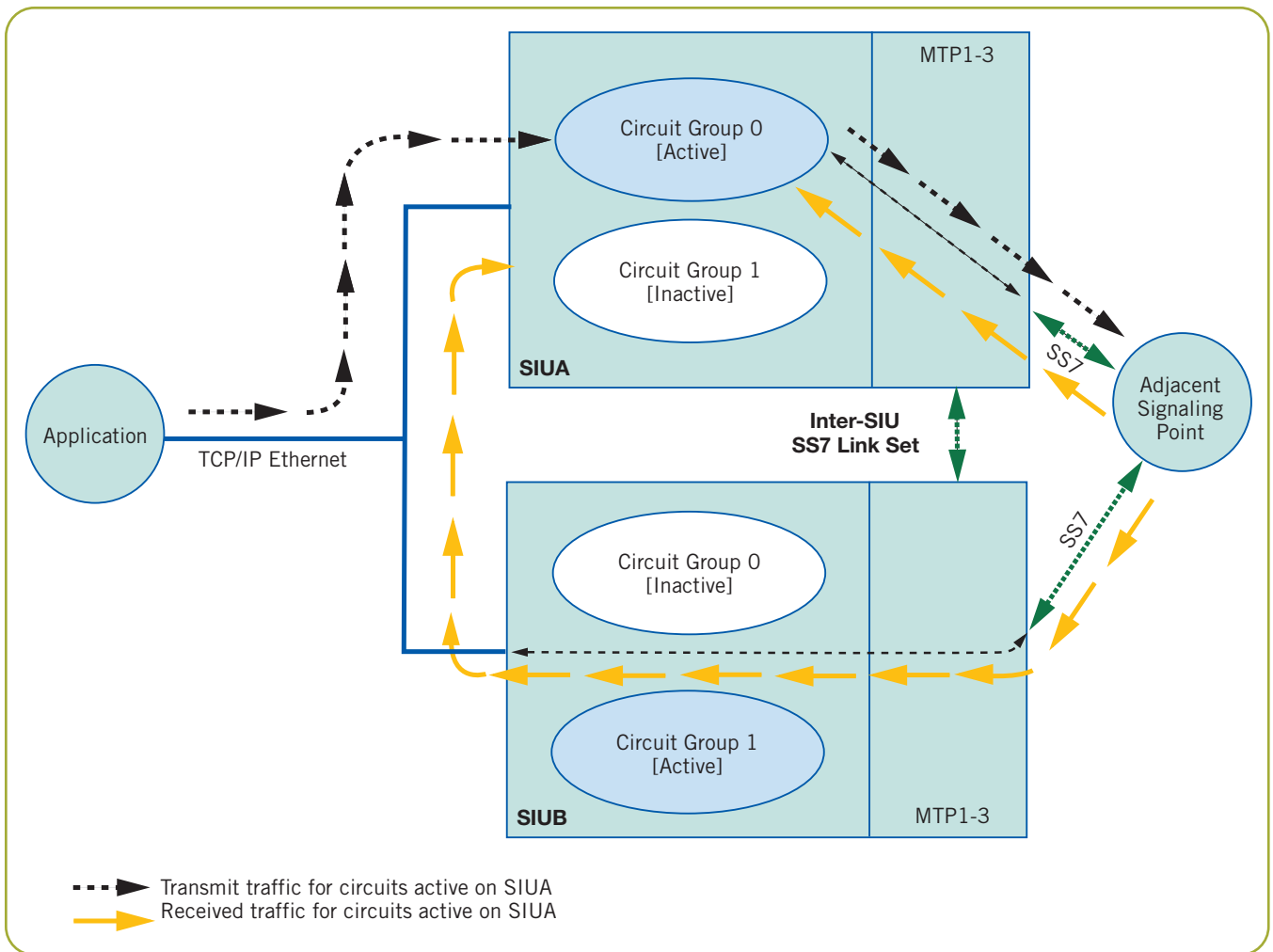

Figure 10. Normal Routing for Circuit Group 0 When Controlled by SIUA

Dual SIU Architecture for Circuit-Switched Applications

Within the SIU environment, circuits are configured in groups, each group equating to all the circuits multiplexed onto a single E-1 or T-1 PCM trunk. The SIU provides the SS7 circuit control and the application platform (or host) terminates the physical channels, typically with a voice processor.

For normal operation, half the circuit groups are controlled by SIUA and half by SIUB. As each application platform starts up and connects to both SIUA and SIUB, the application must nominate which SIU is to control the signaling for each of the circuit groups it

terminates. A circuit group activation command must be sent to the selected SIU for each circuit group. Any outgoing messages for circuits in this group must be sent to this SIU (see Figure 10).

The adjacent signaling point views the links connected to SIUA and SIUB as the same link set and, as such, is free to send messages for the circuits controlled by SIUA to either unit. In the case where SIUB receives a message for a circuit controlled by SIUA, the message is automatically routed to the correct controlling circuit group using the LAN Ethernet connection (shown by the shaded arrows in Figure 10).

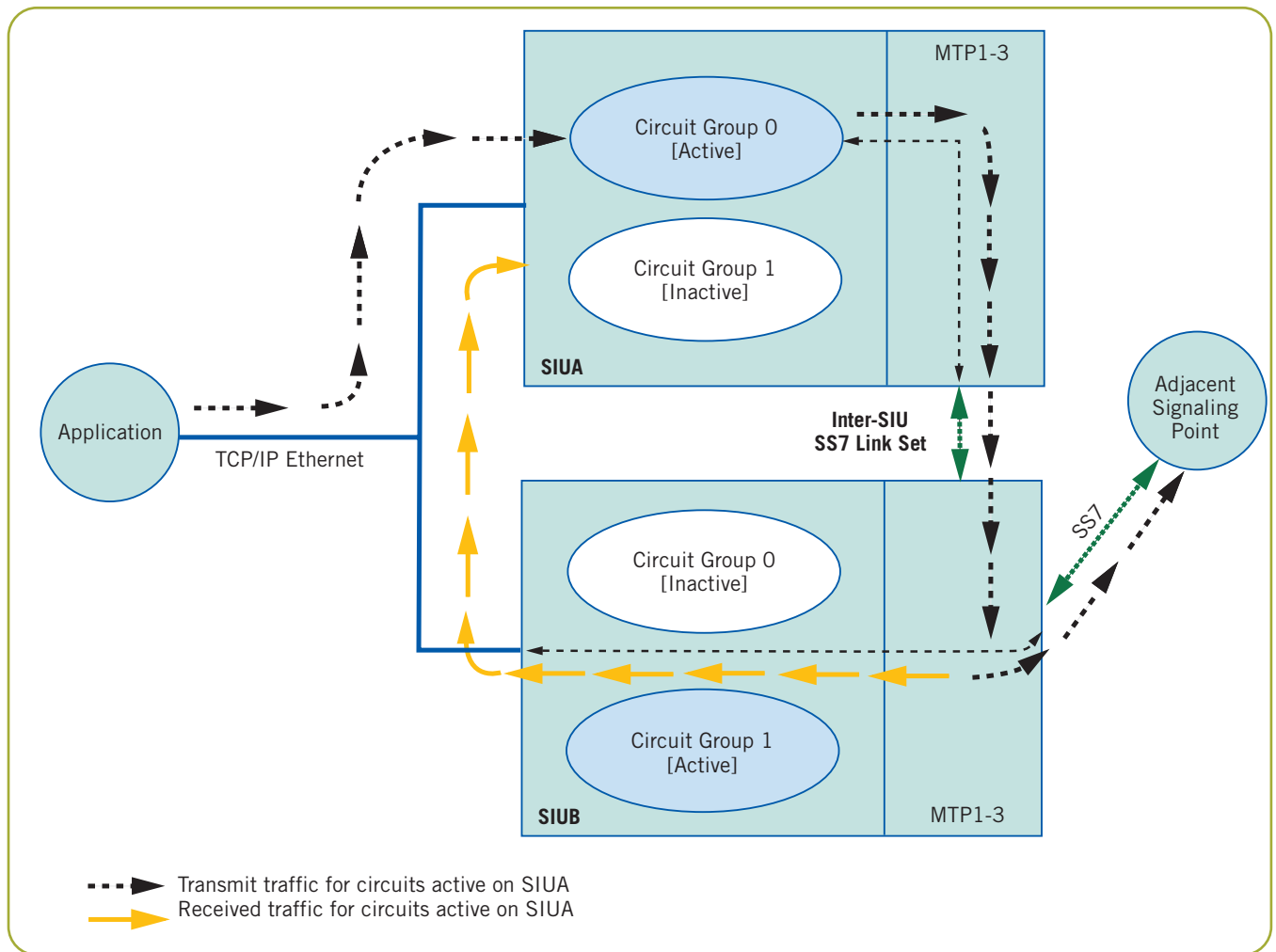

Figure 11. Routing When All Local Links Have Failed, Group 0 Controlled by SIUA

If all the links between the controlling SIU and the adjacent signaling point fail, all transmit traffic is automatically routed to the adjacent signaling point through the inter-SIU link set (see Figure 11). The application should continue to use the SIU as before, directing all outgoing circuit requests to SIUA.

If the controlling SIU fails, the application is informed of the failure and should transfer control of the circuit group to the remaining unit.

- Calls in a steady state (speech) will continue uninterrupted.
- Outgoing calls in a set-up state during the transfer should be re-attempted.
- Incoming calls being set-up by the interconnected SS7 equipment will also fail and will be re-attempted remotely.

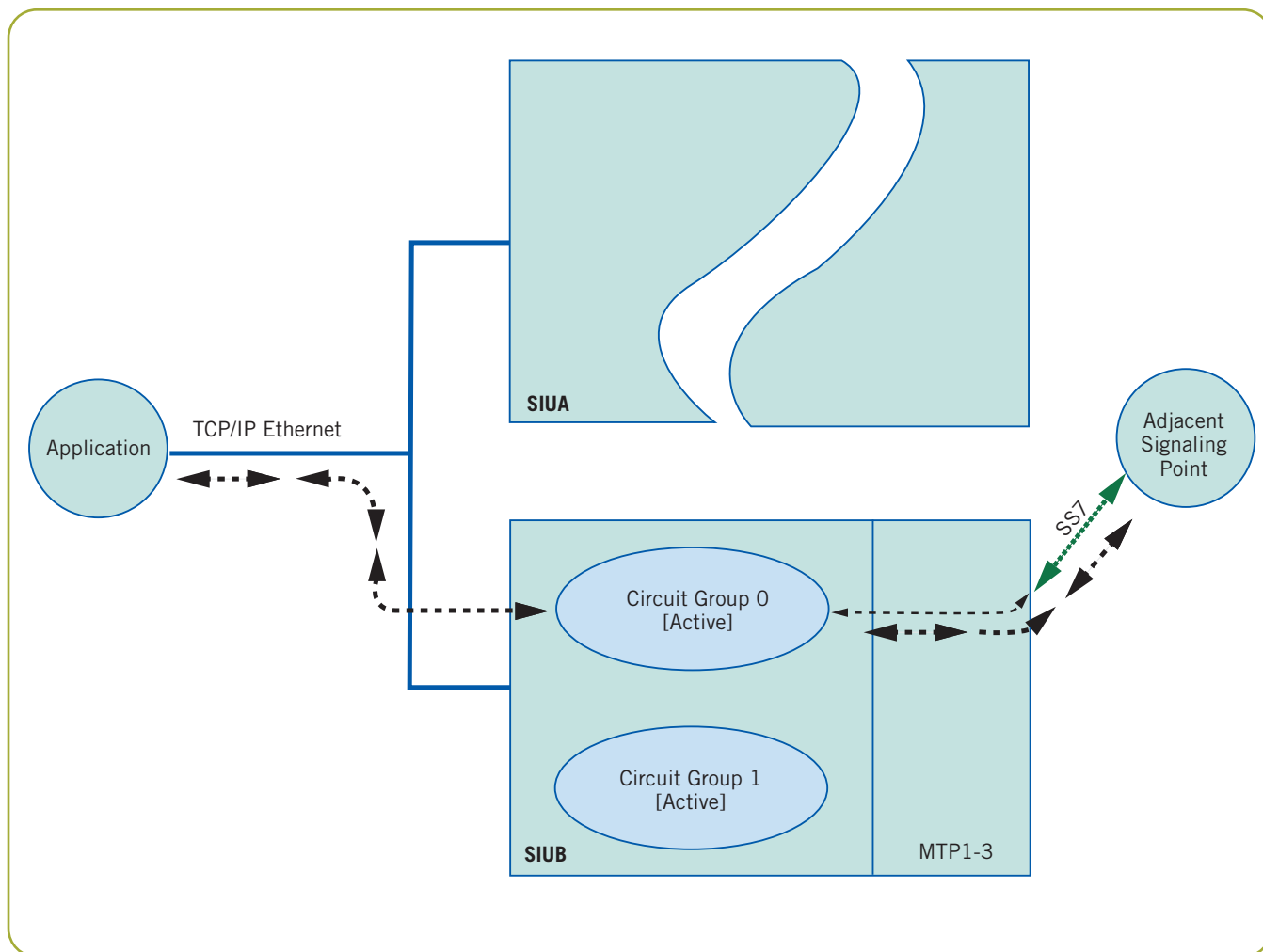

Figure 12. Routing Following Failure of SIUA

The circuit group control will then appear (see Figure 12).

The user application software should reset all idle circuits following a transfer, and reset all remaining circuits as they become idle.

When the failed unit recovers, control of the circuits may be transferred back by the application.

Circuit group control is transferred by the application in two stages. The group should be deactivated from one unit (if communication with that unit is possible) before being activated on the partner SIU. To protect against control being active on both units at the same time, the SIU automatically issues a deactivate command to the partner unit in response to an activate command from the host application and checks the status of each circuit group on the partner unit. An API management event indication is given if dual control is detected.

Dual SIU Architecture for Transaction-Based Applications

There are two ways of architecting a dual-resilient SIU-based system for processing TCAP transactions.

1. Running the SS7 stack up to TCAP on the SIUs
2. Running the SS7 stack up to SCCP on the SIUs

In the first case, each unit controls half of the total available transactions. The Dialogic SS7G2x SIU supports up to 65,536 transactions. Consequently, a dual-resilient system can handle up to 131,072 (that is, 2 x 65,536) simultaneous transactions. Each transaction is processed for its entire duration by the SIU that processed the first TCAP message. The user application must therefore direct all messages for a transaction to the same SIU, and load balance outgoing dialogues between the two units. An incoming TCAP dialogue message other than BEGIN or QUERY is handled by the SIU that processed the first TCAP message for that dialogue received from the SS7 network. When an SIU receives a TCAP message that

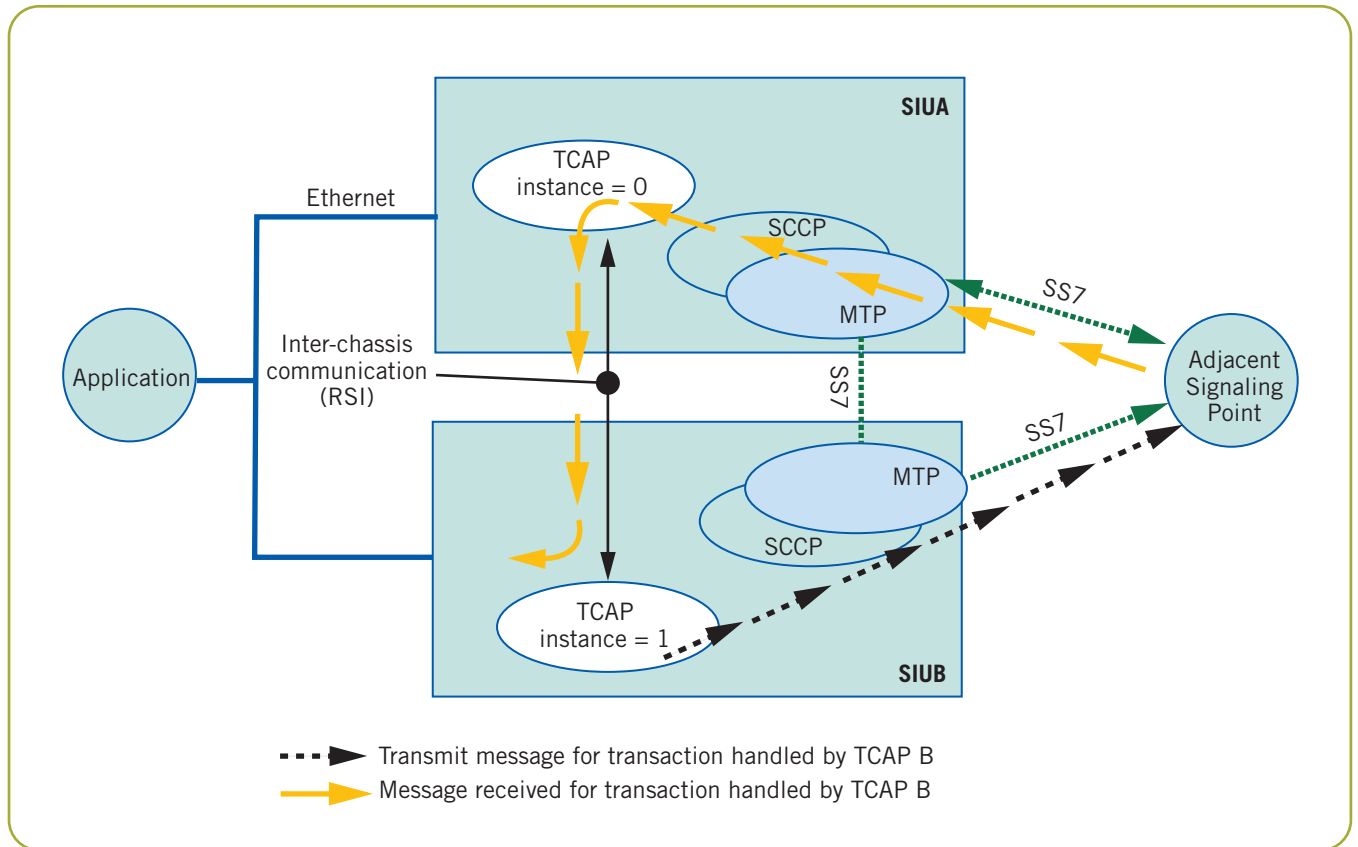

Figure 13. Message Flow on a Dual-Resilient System Running the SS7 Stack up to TCAP

belongs to a transaction that was initiated on the other unit, it will pass this message to its peer SIU over the RSI connection. This is shown in Figure 13. Failure of an SIU reduces the number of available transactions by one-half.

In the second case, TCAP and potential layers sitting on

top of TCAP run on the application host(s), and an additional piece of software is required on each SIU to distribute TCAP transactions to multiple application hosts. This software option is called distributed transaction server (DTS). Figure 14 depicts this architectural difference.

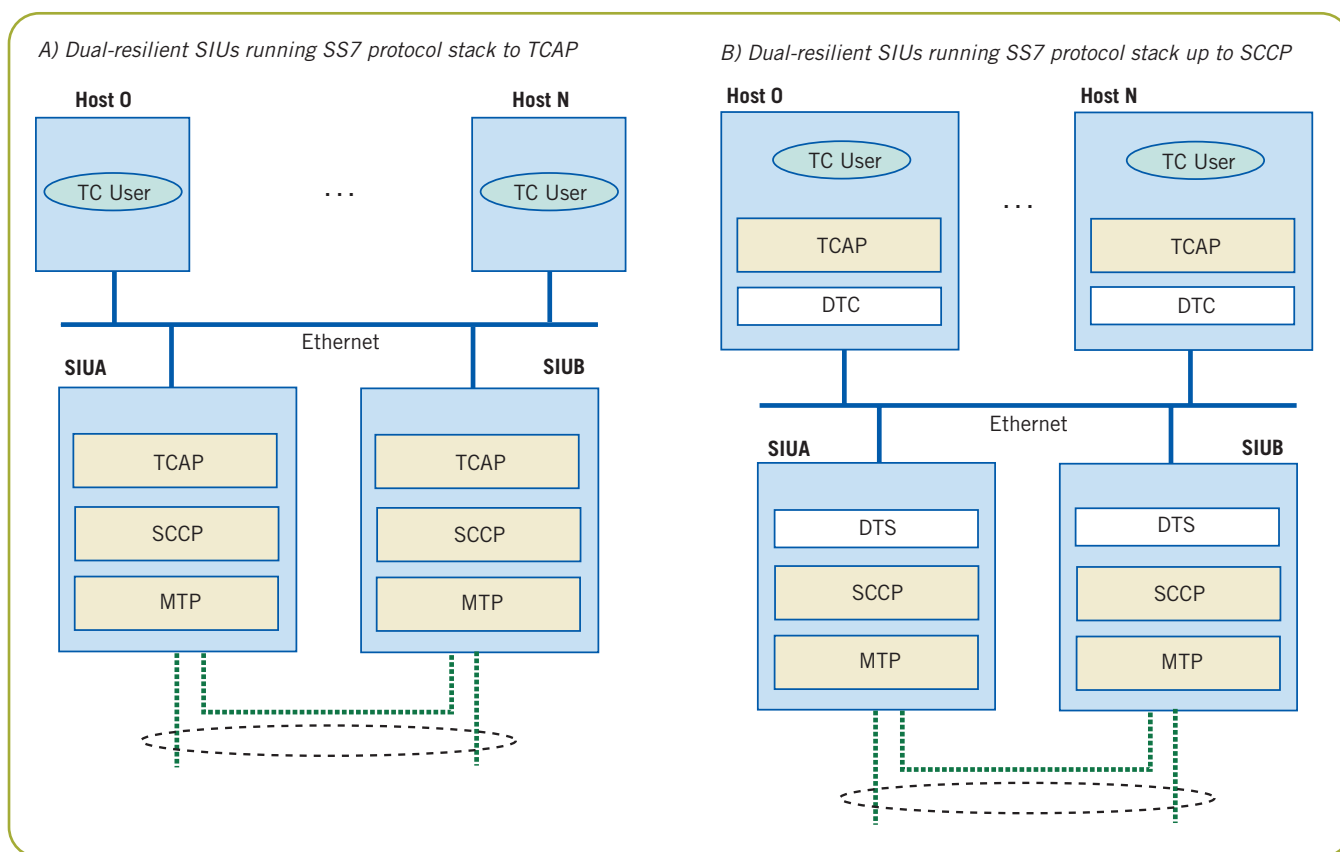

Figure 14. Two Different Architectures for a TCAP Processing SIU System

In a dual-resilient transaction-based SIU system running the SS7 stack up to SCCP on the SIU, and TCAP (and above) on the application host, each host controls a fixed number of transactions. Each transaction is processed for its entire duration by the application host that processed the first TCAP message. Upon failure of one SIU unit, the TCAP capacity and ongoing transaction are totally unaffected.

The architectural decision taken on where the TCAP module is running also has consequences on the level of application resiliency and total system capacity. These consequences are explained in more detail in “Failure of Application” below.

Failure of IP Connection

Problem — Should one IP connection go down due to a cable failure, hosts connected to the SIU using that particular IP connection will go out of service.

Solution — As of software revision v3.0x, the SS7G2x SIU supports IP teaming. This feature allows for sharing a single IP address between two distinct Ethernet ports. This eliminates the risk of losing IP connectivity in the event of a cable disconnection or Ethernet port failure in the LAN.

Details — Refer to the *Dialogic® SS7G2x Signaling Server: SIU Mode User Manual* for more information on how to set up Ethernet ports in resilient teams.

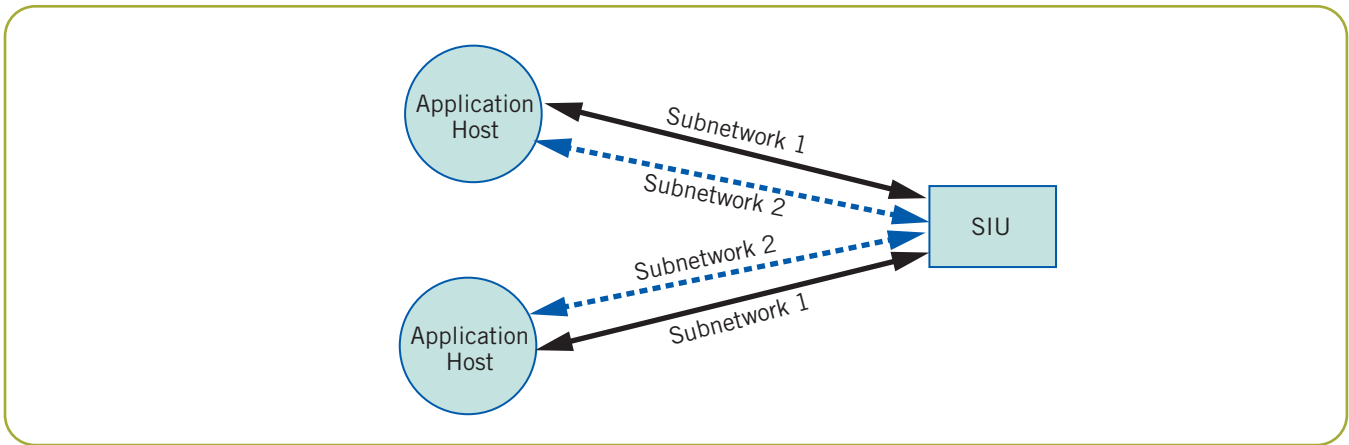

Figure 15. Dual LAN Operation on the SIU

Failure of IP Subnetwork

Problem — Should one subnetwork go down due to a network component failure, the hosts connected to the SIU over the other subnetwork will remain active and will attempt to preserve half of the total system capacity.

Solution — There are four Ethernet ports on the SS7G2x platform. This allows splitting the IP connections between the SIU and the application hosts onto two physically separated subnetworks (see Figure 15). This eliminates the risk of losing all IP connectivity in the event of a switch/router/hub failure in the LAN.

Details —“Failure of Application” below details how to take advantage of the dynamic configuration features offered by the SIU to failover the affected application hosts to the surviving subnetwork.

Failure of Application

Problem —The failure of an application host leads to the loss of a portion of system resources.

Solution —The application can be deployed on multiple hosts; in particular, the SS7G2x SIU supports up to 64 application hosts. For circuit-switched applications, failure of a host generally results in loss of the physical trunk interface; hence, there is no need to transfer the logic to other (surviving) hosts. Nevertheless, the ISUP heartbeat mechanism allows the SIU to automatically block the circuit groups affected by the loss of their controlling hosts. The feature is optional and is activated by setting bit 9 in the <options2> parameter of the ISUP_CFG_CCTGRP command. When the bit is set, heartbeat messages are generated and sent to the user_id configured for the circuit group. If the option is not set,

automatic blocking of circuits is not performed for the circuit group and heartbeat messages are not sent to the user application. More sophisticated features are available to allow TCAP-based applications to failover to other hosts.

Details — For TCAP-based applications, the SIU allows operation of multiple application hosts interfacing directly to TCAP, giving a certain level of resiliency in the user application space. Two TCAP resiliency methods are explained here.

TCAP Resiliency Based on Dialogue Groups

Fixed ranges of TCAP dialogues can be created in the SIUG2x configuration file and assigned to different application hosts. (TCAP dialogue groups are defined using the TCAP_CFG_DGRP command in config.txt. More information about this command can be found in the *Dialogic® SS7G2x Signaling Server: SIU Mode User Manual*.) The application program running on each host must therefore ensure that only dialogue identifiers from the assigned range are used. Optionally, a TCAP-user layer such as MAP, INAP, or IS41 can run on each application host to provide some application part functionalities. Figure 16 describes such a distributed architecture where TCAP transactions are handled by four different hosts, each of them running MAP and a MAP application. The total number of TCAP dialogues for the whole system is 65,536, and this number does not depend on the number of hosts.

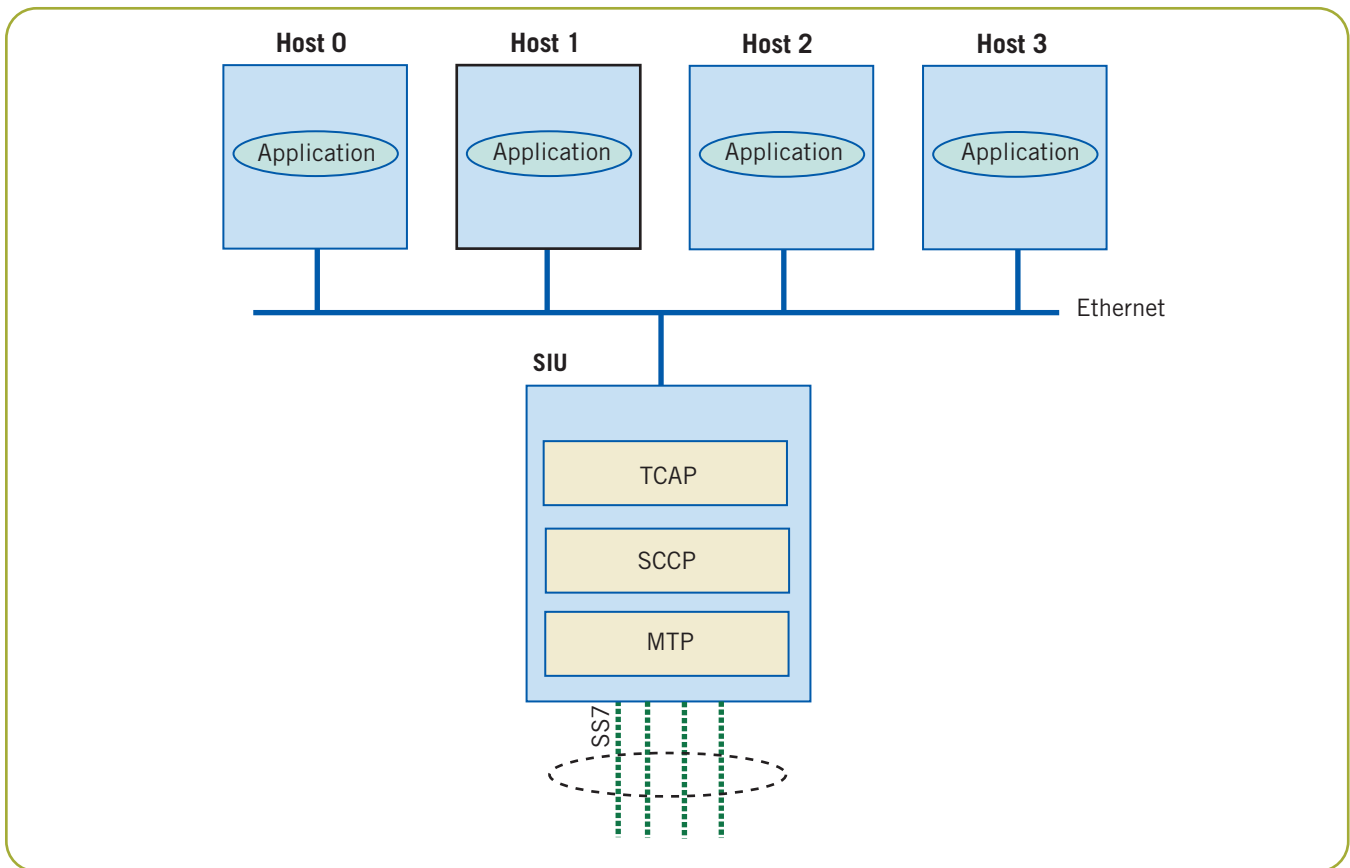

Figure 16. TCAP Dialogue Groups Example

TCAP Resiliency Based on DTS/DTC Option

Alternatively, it is possible to distribute SCCP traffic to multiple application hosts using the distributed transaction server/distributed transaction client (DTS/DTC) software option, as shown on Part B of Figure 13. In this architecture, TCAP and potential application parts run on each application host. Consequently, the total capacity of such a system depends on the number of application hosts, with each host bringing an increment of 65,536 simultaneous dialogues. Refer to the *Dialogic® SS7 Protocols DTS User Guide* for more information on the DTS/DTC software option.

Configuring a Dual SIU Pair

To create a dual-resilient configuration for the Dialogic SS7G2x SIU, modify both the system configuration (done using the man machine interface [MMI]) and the protocol configuration (in the config.txt parameter file). This is done remotely and transferred to the SIU using FTP. More details may be found in the *Dialogic® SS7G2x Signaling Server: SIU Mode User Manual*.

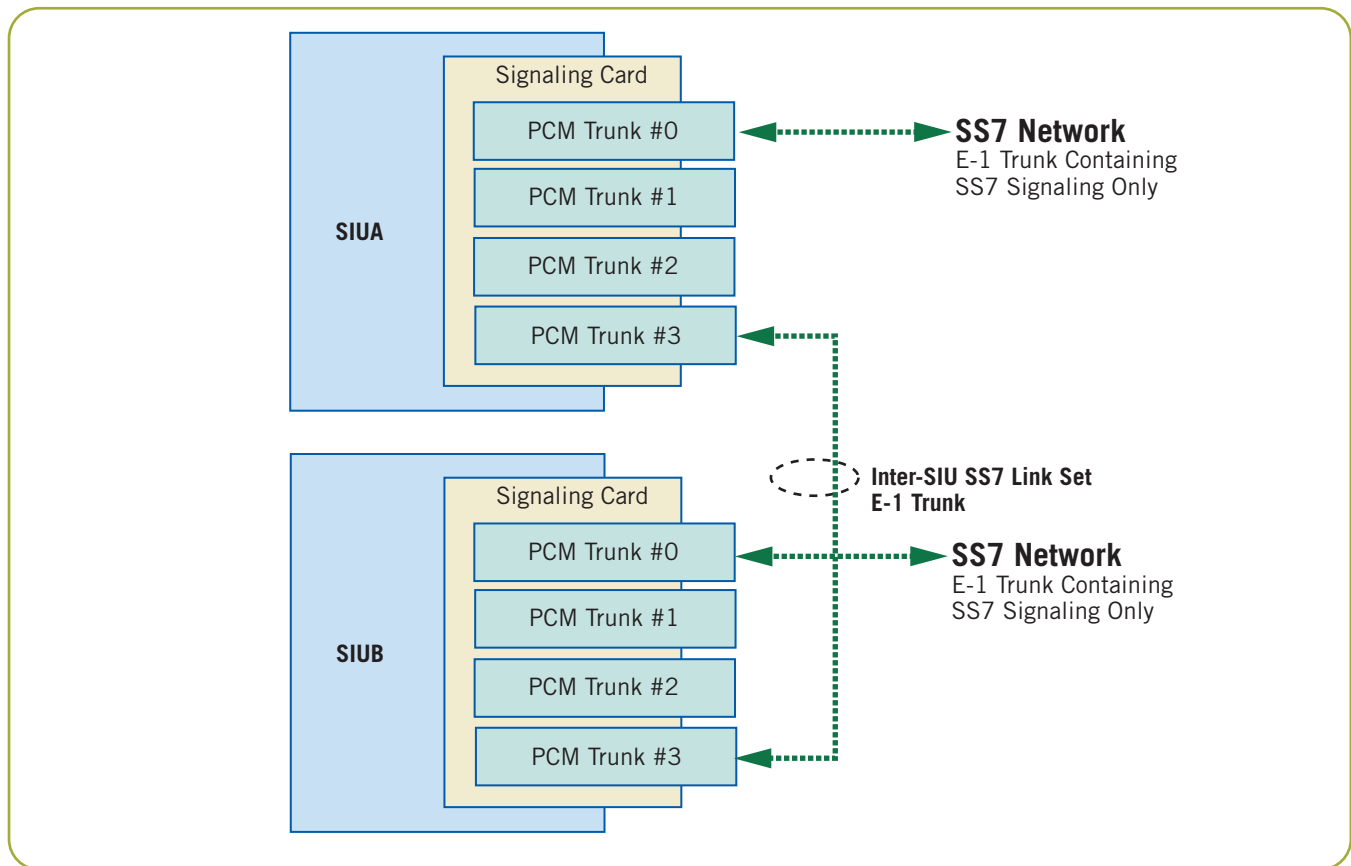

Figure 17. Inter-SIU Link over Crossed E-1/T-1 Cable

Hardware Requirements

Configuring an SIU as one-half of a resilient pair requires additional hardware ports to carry the inter-SIU link set between SIUA and SIUB. This may be achieved using E-1/T-1 interfaces (see Figure 17), or IP (SIGTRAN) interfaces (see Figure 18) (assuming the SIU is running software version V4.00 or later).

The inter-SIU signaling link set can be configured to use any signaling processor on any signaling card and may be carried on any of the available interfaces on the signaling card.

System Configuration

The system assignment of SIUA or SIUB is made by typing one of these commands:

```
CNSYS:MODE=SIUA;
or
CNSYS:MODE=SIUB;
```

The current assignment may be displayed by typing:

```
CNSYP;
```

Changes to the config.txt Parameter File

Each SIU is configured individually. The config.txt parameter file held on each unit reflects the configuration view of the local unit only; hence, assignments of link set and link identities are only unique within a single unit.

For the dual configuration, the IP address of the other SIU must be declared using the `SIU_REM_ADDR` command.

Configuring the Inter-SIU Link

The inter-SIU link set should be defined on both units using the `MTP_LINKSET` command with bit 15 of the `<flags>` parameter set to 1. This link set must have the same value defined for the `<local_spc>` and `<adjacent_spc>` values; this will be the local point code of the SIU pair. Links are added to the inter-SIU link set using the `MTP_LINK` command, assigning incremental

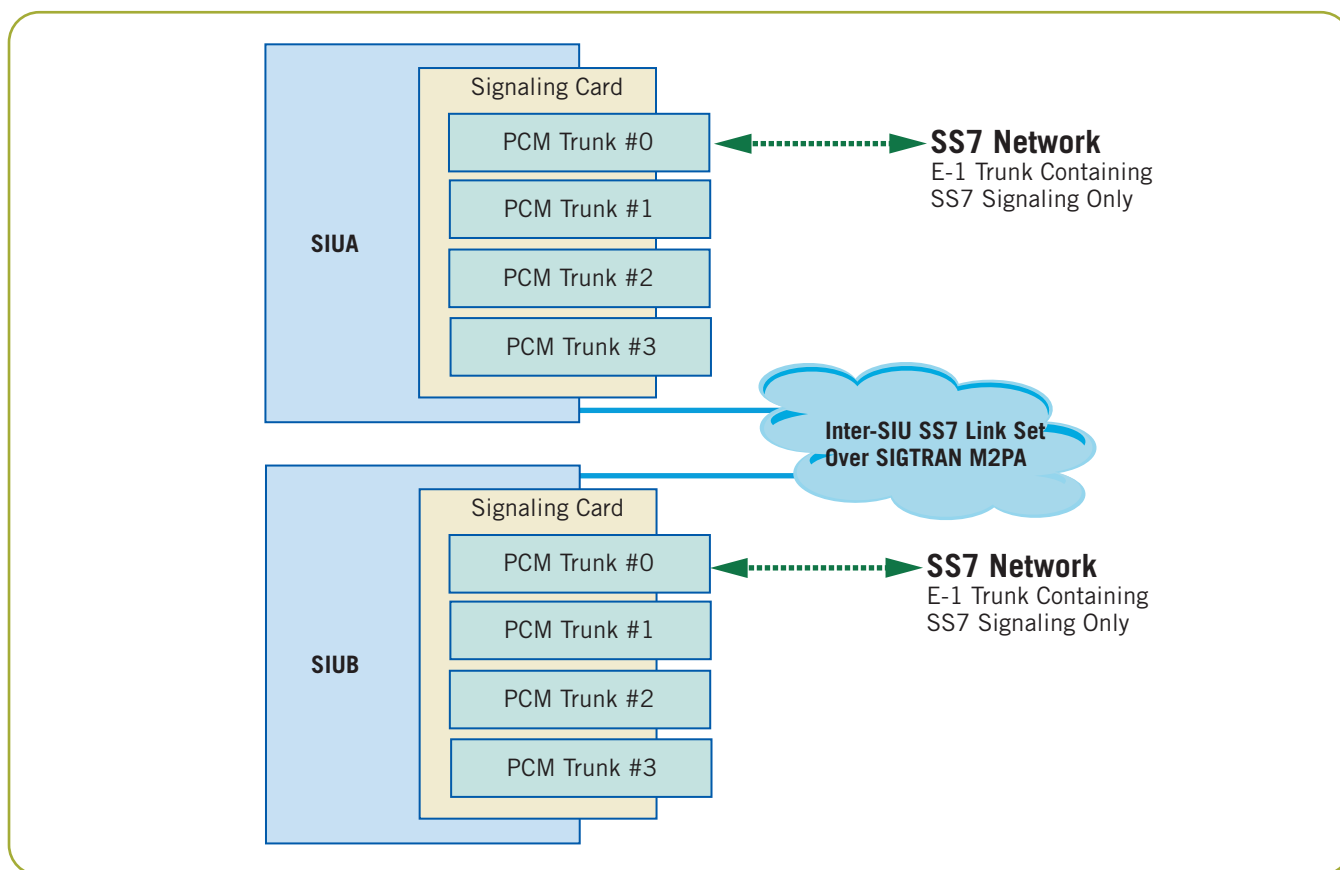

Figure 18. Inter-SIU Link Set over IP (using SIGTRAN M2PA)

<link_ref> and <slc> values as normal. The <bpos> and <blink> parameters define which SS7 processor manages each link.

For a link using a PCM port, the physical location of the link is specified by setting the <stream> and <timeslot> parameters.

To use a SIGTRAN M2PA link, the **MTP_LINK** <flags> bit 31 should be set to 1, with a previously configured M2PA link identified by the <blink> parameter.

Routing Configuration

A route should be defined on both SIUA and SIUB for the inter-SIU link set using the **MTP_ROUTE** command referencing the appropriate <linkset_id> with a <dpc> value set to the point code of the SIU pair. This route may only be specified to operate over a single link set.

Each DPC that may be accessed from the application must have an accompanying **MTP_ROUTE** declaration. For dual operation, each route includes a preferred link set, the <linkset_id> parameter, and a secondary link set specified by <second_ls>. **linkset_id** should reference the link set connecting the SIU to the appropriate adjacent signaling point, **second_ls** must be set to the **linkset_id** assigned to the inter-SIU link set.

Circuit Group Configuration

For dual operation, each SIU contains identical circuit group declarations using the appropriate **ISUP_CFG_CCTGRP** or **TUP_CFG_CTGRP** commands. These circuit group configurations do not become active on either unit until an Activate Circuit Group API command has been issued to a particular SIU.

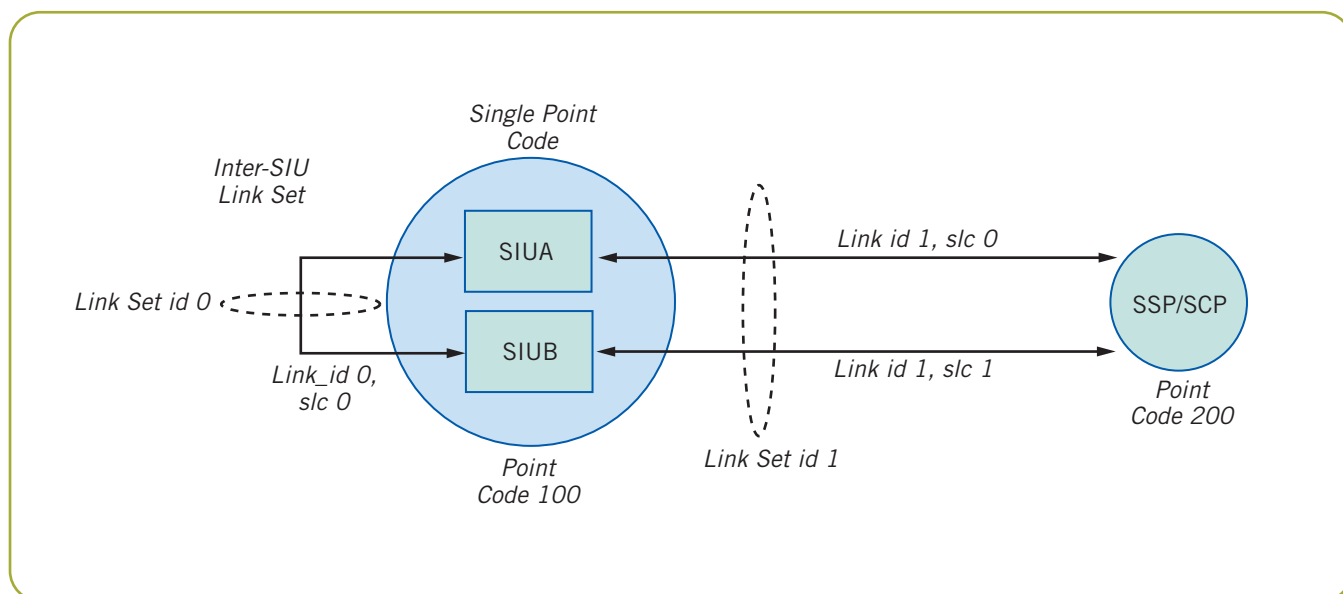

Figure 19. Example Configuration to an Adjacent SSP/SCP

Example Configuration

To define routing to the DPC 200 below (which is also the adjacent point code), using the first E-1 port on the first signaling card in an SIU, the configuration (Figure 19) would be:

For SIUA

```
MTP_CONFIG 0 0 0x0000
MTP_LINKSET 0 100 1 0x8000 100 0x8
MTP_LINKSET 1 200 1 0x0000 100 0x8
MTP_LINK 0 0 0 0 1 1 1 1 0 0x4006
MTP_LINK 1 1 0 0 1 2 1 2 16 0x0006
MTP_ROUTE 100 0 0x0020
MTP_ROUTE 200 1 0x0020 0x0001 0
```

For SIUB

```
MTP_CONFIG 0 0 0x0000
MTP_LINKSET 0 100 1 0x8000 100 0x8
MTP_LINKSET 1 200 1 0x0000 100 0x8
MTP_LINK 0 0 0 0 1 1 1 1 0 0x6006
MTP_LINK 1 1 0 1 1 2 1 2 16 0x0006
MTP_ROUTE 100 0 0x0020
MTP_ROUTE 200 1 0x0020 0x0001 0
```

(up_enable was set for ISUP, user part SI = 5 for the example above)

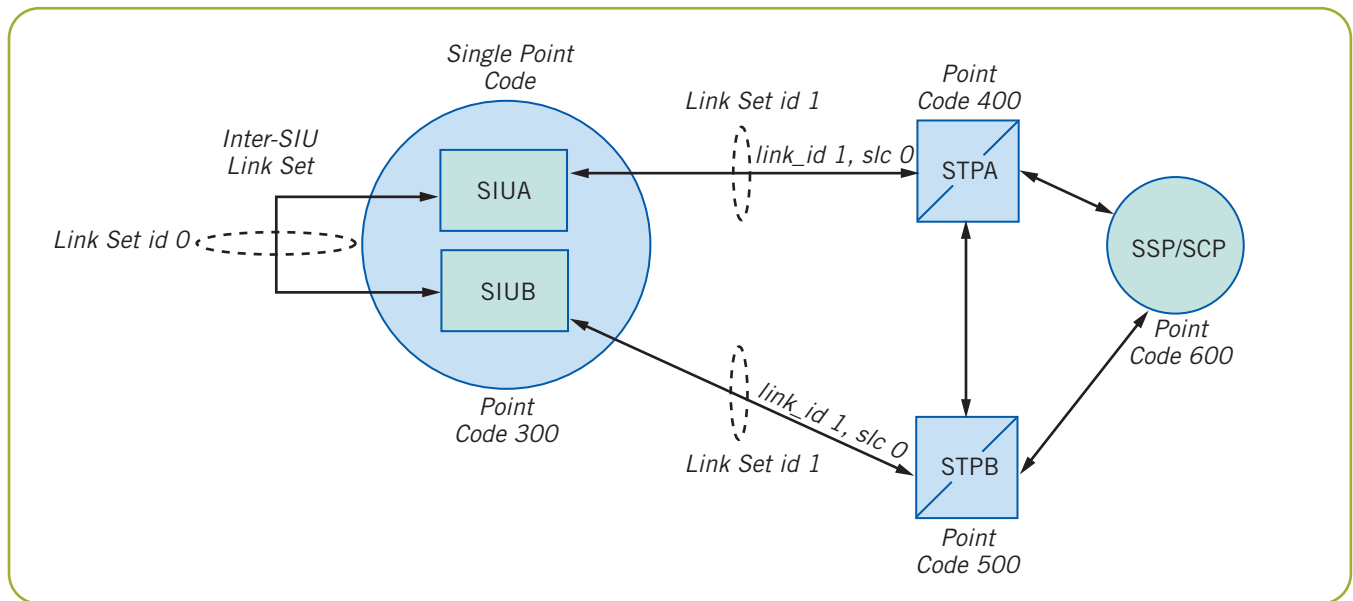

Figure 20. Example Configuration to an Adjacent STP Pair

For an SIU pair connected to a mated STP pair, carrying the inter-SIU link over the second E-1 port of the first signaling card the configuration (Figure 20) would be:

For SIUA

```
MTP_CONFIG 0 0 0x0000
MTP_LINKSET 0 300 1 0x8000 300 0x8
MTP_LINKSET 1 400 1 0x0000 300 0x8
MTP_LINK 0 0 0 0 1 1 1 1 0 0x4006
MTP_LINK 1 1 0 0 1 2 1 2 16 0x0006
MTP_ROUTE 300 0 0x0020
MTP_ROUTE 400 1 0x0020 0x0001 0
MTP_ROUTE 500 1 0x0020 0x0001 0
MTP_ROUTE 600 1 0x0020 0x0001 0
```

For SIUB

```
MTP_CONFIG 0 0 0x0000
MTP_LINKSET 0 300 1 0x8000 300 0x8
MTP_LINKSET 1 500 1 0x0000 300 0x8
MTP_LINK 0 0 0 0 1 1 1 1 0 0x6006
MTP_LINK 1 1 0 0 1 2 1 2 16 0x0006
MTP_ROUTE 300 0 0x0020
MTP_ROUTE 400 1 0x0020 0x0001 0
MTP_ROUTE 500 1 0x0020 0x0001 0
MTP_ROUTE 600 1 0x0020 0x0001 0
```

Run-Time Operations of a Dual-Resilient SIU System

Connecting a Host to Two SIUs

In a dual SIU system, each host should connect to both SIUA and SIUB at start-up. This is achieved using the `rsicmd` utility twice: first with an `siu_id` of 0 for SIUA and second with an `siu_id` of 1 for SIUB. For example, if SIUA has an IP address of 123.234.345.110 and SIUB an IP address of 123.234.345.220, the entry in the host's system configuration file, `system.txt`, would be:

```
FORK_PROCESS rsicmd 0 0xef 0
123.234.345.110 9000

FORK_PROCESS rsicmd 1 0xef 0
123.234.345.220 9000
```

The “concerned module id” (0xef in this case) will receive status indications from the rsi process for both connections. The id field of the MSG header is set to the `siu_id` to identify the link to which each status indication relates.

The ability to communicate between a host and an SIU is indicated by `RSI_MSG_STATUS` messages received by the `conc_id` application process (0xef in this case).

Communicating with Both SIUA and SIUB

The user application exchanges information with the SIU via API messages (MSG). In a dual SIU environment, each time the user application sends a message to the SIU, it is directed to either SIUA or SIUB using a library function `GCT_set_instance`. In the receive direction, the application can determine the SIU that sent a MSG using the library function `GCT_get_instance`. Function definitions may be found in the header file `sysgct.h`.

GCT_set_instance

```
int GCT_set_instance(unsigned int
instance, HDR *h);
```

This function sets the destination instance number (SIU identity or `siu_id`) prior to sending a message and returns 0 on success, non-zero otherwise (currently no failure conditions are defined). SIUA is instance 0 and SIUB is instance 1, assigned by the `siu_id` parameter provided to the `rsicmd` utility. This function should be called immediately before `GCT_send`.

GCT_get_instance

```
unsigned int GCT_get_instance(HDR *h);
```

This function returns the instance number (SIU identity or `siu_id`) after receiving a message. The parameter `h` is a pointer to the HDR structure at the start of the received MSG. The returned value will be either 0 or 1. SIUA is instance 0 and SIUB is instance 1, as assigned by the `siu_id` parameter provided to the `rsicmd` utility.

Transferring Control of a Circuit Group between SIUs

Activating and Deactivating Circuit Groups

Configuration commands for all circuit groups must be present on both SIUs. At run time, the application running on each host selects which SIU is currently in control of each group by “activating” and “deactivating” groups on a particular SIU.

Circuit groups are activated and deactivated using the `API_MSG_COMMAND` message (type 0x7f0f), with a `cmd_type` of 8 to activate a group and a `cmd_type` of 9 to deactivate a group. The format of this message is detailed in the *Dialogic® SS7G2x Signaling Server: SIU Mode User Manual*. This message should be issued with a request for a response (an acknowledgement); this will be returned to the requesting application with a status value of zero (indicating “success”) or with non-zero values (indicating “busy” or “failure”).

System Initialization

When the system starts up, the host establishes communication with both SIUA and SIUB, either by using the `rsicmd` utility or by issuing RSI configuration API messages directly from within the application.

When the communication between the host and the SIU is established, the RSI task on the host issues an `RSI_MSG_LINK_STATUS` API message with a status value set to 1 (link to SIU recovered) to a destination task `conc_id` on the host (`conc_id` is set when the RSI link was started). This message will only be received by the application if the RSI link is configured with the `conc_id` set to the application's module ID.

The ID field of this message is set to 0 to indicate SIUA and to 1 to indicate SIUB. When the link to the SIU that normally controls a circuit group (the primary SIU) becomes active, the application should issue an activate group command to that SIU, specifying that circuit group

(using its group ID). The SIU processes API commands sequentially and the application must wait for an acknowledgement of this command before proceeding. An acknowledgement that indicates “busy” should cause the application to re-attempt the activate command.

The application should wait for a period of time sufficient to establish communication to the preferred SIU before deciding that the preferred unit is not available and then activating circuit groups on the non-preferred or secondary SIU.

Once the acknowledgement of the activation of a circuit group is received, the circuits should be reset to force the circuits into a known, idle state. This is achieved using the **Circuit Group Status Control (CGSC) Request** API message, detailed in the appropriate *Programmer's Manual*. The circuit reset is acknowledged by the terminating exchange; this acknowledgement is passed to the user application as a circuit group status confirmation API message. On receipt of this acknowledgement, the application may commence using the associated circuits for calls.

Failure Detection

The event that triggers the application to transfer circuit groups from one SIU to another is loss of communication between the application and the SIU.

When such a failure occurs, the RSI task on the affected host detects the loss of communication and issues an **RSI_MSG_LINK_STATUS** API message with a status value set to 2 (link to SIU lost) to a destination task **conc_id** on the host (**conc_id** is set when the RSI link was started, optionally by **rsicmd**). This message will only be received by the application if the RSI link is configured with the **conc_id** set to the application's module ID.

At the same time, the affected SIU will issue, if it can, an **API_MSG_SIU_STATUS** message with status value 30 (decimal) indicating a host link failure on the specified host ID. This message is sent to the host configured to receive management messages (host 0 by default).

There are two failure modes that can cause loss of communication:

- Complete failure of one SIU in a dual-resilient pair
- Partial TCP/IP failure causing loss of communication between the host and one SIU of the pair via the TCP/IP LAN

From the application's point of view, there is no difference in these cases since the RSI link fails in either case. From a system point of view, the main difference is that in the second case, the inter-SIU communication may still be functioning.

If the affected SIU loses communication with all of its hosts, it automatically deactivates all SS7 signaling links, preventing any messages from being processed by any remaining active circuit groups.

Transferring the Circuit Group

If any of the circuit groups terminating on the host are currently active on the affected SIU, the host application transfers control of each affected circuit group from the failed SIU (the primary SIU) to the remaining SIU (the secondary SIU). Transferring a circuit group normally involves deactivating the group on the controlling SIU then reactivating it on the other. However, since the host is unable to communicate with the failed SIU, the application is only required to send an **API_MSG_COMMAND** message to the secondary SIU with **cmd_type** of 8 (activate circuit group) for each affected group.

The activate circuit group command should be issued with a request for a response and the application should not send any call processing or circuit management commands until the response (acknowledgement) has been received from the secondary SIU.

The SIU processes single commands in sequence; therefore, if an activate command is received while a previous command is executing, the response will be received with a non-zero status (in this case, a value of 4 indicating “equipment busy”). The application should reattempt the activate command on receipt of a response indicating “busy”.

Since the failure may affect SIUA and SIUB, the host may choose to wait for a period of time following notification of the failure to determine if communication with the other unit remains stable. The circuit groups may then be transferred after this timeout if the communication to the secondary unit remains active.

Re-synchronization of Circuit State Information

Once the circuit group activation(s) are acknowledged from the secondary SIU, the application needs to resynchronize the circuit state information based on the application's knowledge of the current circuit state. This is achieved by sending three CGSC requests to the secondary SIU.

Circuits that were in a call set-up state or were idle (that is, any circuit that was not in the steady state "speech" or "answered" state) should be RESET. Circuits that were in the speech stage of an incoming call should be forced to INCOMING ACTIVE; circuits that were in the speech state of an outgoing call should be forced to OUTGOING ACTIVE. Forcing the circuit state to either INCOMING ACTIVE or OUTGOING ACTIVE is achieved using the `ISP_MSG_CGSC_REQ (0x7703)` API message, with `p_type` set to 14 (decimal) for INCOMING ACTIVE and 15 (decimal) for OUTGOING ACTIVE.

Calls that were in outgoing set-up prior to the transfer should be re-attempted following successful completion of the transfer. The application should be able to re-attempt a failed outgoing call attempt, as this may occur under normal operating conditions. The originating switch will automatically reattempt calls that were in incoming set-up. When these commands are acknowledged, the application may resume normal call activity.

Note: The TUP protocol does not support forcing of circuit states to INCOMING ACTIVE or OUTGOING ACTIVE, so this step should be omitted. No additional signaling should be exchanged for TUP calls that were in the answered state following the transfer. In this case, OUTGOING ACTIVE calls should be released (at the appropriate time) with a circuit reset.

Recovery of the Failed Unit

The host application is informed of recovery of the communication to the SIU via the same method used for notification of the failure. The `RSI_MSG_LINK_STATUS` message in this case contains a status value of 1 (link to SIU recovered).

The host nominated to receive management indications (normally host 0) will also receive an `API_MSG_SIU_STATUS` message with status value 31 (decimal) indicating a host link has recovered to the specified host ID.

Transferring Control Back

Immediately following re-establishment of communication with the primary SIU, the application should send deactivate circuit group messages to this SIU to ensure that groups are only active on the secondary unit (this may be the case if the inter-SIU link had also failed). If the primary unit has recovered from a complete failure, no circuit groups will be active. This deactivate command will fail if the groups were not active, and the application should ignore any acknowledgement of this command with a status value indicating processing failure. A "busy" response should cause the application to reattempt the deactivate command.

When communication with the primary SIU has been re-established, the application should allow sufficient time to ensure that the communication is stable, thus avoiding repeatedly transferring circuits between units. After this time has expired, the application should transfer control of the affected circuit groups back to the original SIU.

This is achieved by deactivating the groups on the secondary SIU and re-activating the ones on the primary SIU. However, before the groups are deactivated, the circuits in that group should be maintenance blocked. (Using the **Circuit Group Supervision Control API** message). This does not affect any calls in progress, but will prevent these circuits from being selected for any new incoming calls. The application should also ensure that none of the affected circuits are selected for new outgoing calls.

When all existing calls are completed (all the circuits are therefore idle), the application should deactivate the circuit group by sending an `API_MSG_COMMAND` message with `cmd_type` of 9 to the secondary unit. When the acknowledgement that this command has been successfully processed has been received, the groups should be activated on the primary unit by sending an `API_MSG_COMMAND` message with `cmd_type` of 8.

Once the acknowledgement of the activation has been received by the application, all affected circuits should be reset. This will force the circuits to a known (idle) state and remove the blocking status. When the reset is acknowledged from the terminating switch (by receipt of a circuit group supervision control confirmation message) the application may begin exchanging call traffic with the SIU.

Circuit Group Conflict

Both SIUs in a dual-resilient configuration periodically poll each other to determine which circuit groups are active on each unit. If a group is active on both units at the same time, an `API_MSG_USER_EVENT` message is issued by the unit that detects the conflict, indicating the group ID of the affected circuit group. The controlling application host should issue a deactivate command to the SIU that should not be controlling the circuit group and re-synchronize the circuits in the group (on the correct SIU) by issuing a reset.

The SIUs prevent this situation from arising by automatically sending a deactivate circuit group command to the other unit on receipt of the activate command. If the nature of the failure is such that inter-SIU communication is lost, it may be impossible for the SIU to issue the automatic deactivate command. Under this circumstance, when the failed SIU recovers, circuit groups may be active from the time before the initial failure. This situation is handled by the application sending a deactivate command for all of the previously active groups immediately following restoration of the communication with the SIU.

Appendix A: Frequently Asked Questions

- Q: How can I tell if an SIU fails?**
A: The status of the communication between the host and the SIU is indicated by `RSI_MSG_STATUS` messages.
- Q: What happens if an SS7 message for a circuit or transaction is received by an SIU that does not control that circuit or transaction?**
A: The message is automatically passed to the partner SIU using the TCP/IP LAN.
- Q: If a single SS7 link to the network fails on one of my SIUs, does my application need to take any action?**
A: No. If there are other links remaining on that unit, the traffic will change over to one of these; otherwise, the traffic will be automatically passed to the other unit via the inter-SIU SS7 link set.
- Q: If all of the SS7 links to one of the SIUs fail, do I need to take any action?**
A: No. The SIU will automatically re-route transmit traffic via the inter-SIU SS7 link set.
- Q: If an SIU fails, do I need to take any action?**
A: Yes. For switched-circuit applications, the circuit groups controlled by the failed unit should be activated on the remaining unit. Further information may be found in the *Dialogic® SS7G2x Signaling Server: SIU Mode User Manual*.
- Q: What happens if an inter-SIU SS7 link fails?**
A: The SIU will change over to use other SS7 links in the inter-SIU link set
- Q: What happens if the Ethernet interfaces fail on an SIU?**
A: This will cause failure of all of the connections between the hosts and the SIU. The SIU will react by deactivating all connected SS7 links, preventing any more signaling information from being received from the SS7 network. The host applications will receive an indication indicating failure of the SIU and should transfer any circuit groups controlled by this SIU to the remaining unit, with the effective result being as though the complete unit had failed.

- Q: Do I need to activate circuit groups on a single SIU configuration?**
A: No.
- Q: How many links should I configure in the inter-SIU link set?**
A: The inter-SIU link set should have sufficient capacity to enable it to carry the maximum traffic exchanged between a single SIU and the adjacent signaling point. To eliminate single points of failure, more than one link may be configured in the link set, with each link connecting to a different signaling card.

Acronyms

API	Application programming interface
CIC	Circuit identification code
DPC	Destination point code
DTC	Distributed transaction client
DTS	Distributed transaction server
HDD	Hard disk drive
LAN	Local area network
MMI	Man machine interface
PCM	Pulse code modulation
SIU	Signaling interface unit
SCP	Service control point
SSP	Service switching point
SS7	Signaling system 7

For More Information

The following documents are available at <http://www.dialogic.com/support/helpweb/signaling>

Dialogic® SS7G2x Signaling Server: SIU Mode User Manual, Issue 5

Dialogic® SS7G21 and SS7G22 Signaling Servers: Hardware Manual, Issue 5

Dialogic® SS7 Protocols DTS User Guide, Issue 5

To learn more, visit our site on the World Wide Web at <http://www.Dialogic.com>.

Dialogic Corporation

9800 Cavendish Blvd., 5th floor
Montreal, Quebec
CANADA H4M 2V9

INFORMATION IN THIS DOCUMENT IS PROVIDED IN CONNECTION WITH PRODUCTS OF DIALOGIC CORPORATION OR ITS SUBSIDIARIES ("DIALOGIC"). NO LICENSE, EXPRESS OR IMPLIED, BY ESTOPPEL OR OTHERWISE, TO ANY INTELLECTUAL PROPERTY RIGHTS IS GRANTED BY THIS DOCUMENT. EXCEPT AS PROVIDED IN A SIGNED AGREEMENT BETWEEN YOU AND DIALOGIC, DIALOGIC ASSUMES NO LIABILITY WHATSOEVER, AND DIALOGIC DISCLAIMS ANY EXPRESS OR IMPLIED WARRANTY, RELATING TO SALE AND/OR USE OF DIALOGIC PRODUCTS INCLUDING LIABILITY OR WARRANTIES RELATING TO FITNESS FOR A PARTICULAR PURPOSE, MERCHANTABILITY, OR INFRINGEMENT OF ANY INTELLECTUAL PROPERTY RIGHT OF A THIRD PARTY.

Dialogic products are not intended for use in medical, life saving, life sustaining, critical control or safety systems, or in nuclear facility applications.

Dialogic may make changes to specifications, product descriptions, and plans at any time, without notice.

Dialogic is a registered trademark of Dialogic Corporation. Dialogic's trademarks may be used publicly only with permission from Dialogic. Such permission may only be granted by Dialogic's legal department at 9800 Cavendish Blvd., 5th Floor, Montreal, Quebec, Canada H4M 2V9. Any authorized use of Dialogic's trademarks will be subject to full respect of the trademark guidelines published by Dialogic from time to time and any use of Dialogic's trademarks requires proper acknowledgement.

The names of actual companies and products mentioned herein are the trademarks of their respective owners. Dialogic encourages all users of its products to procure all necessary intellectual property licenses required to implement their concepts or applications, which licenses may vary from country to country.

Copyright © 2007 Dialogic Corporation All rights reserved.

07/07 9206-02